

G A M E  R E A D Y®

**加压冷疗系统
GRPro® 2.1
说明书**

This User's Manual can be found online in various languages at
www.gameready.com

يمكن الحصول على هذا الدليل بالعديد من اللغات على الموقع الإلكتروني: www.gameready.com

Dieses Bedienerhandbuch steht auch im Internet unter www.gameready.com
in verschiedenen Sprachen zur Verfügung

Este Manual del usuario está disponible en www.gameready.com en distintos idiomas

本用户手册可以在 www.gameready.com 找到, 在线提供各种语言版本

Denne brugermanual kan findes online på forskellige sprog på
www.gameready.com

Deze gebruikshandleiding is online beschikbaar in verschillende talen, op
www.gameready.com

Tämä käyttöopas on saatavana verkossa useilla eri kielillä osoitteessa
www.gameready.com

Ce manuel d'utilisation est disponible en plusieurs langues sur le site
www.gameready.com

Μπορείτε να βρείτε αυτό το εγχειρίδιο χρήσης, σε ηλεκτρονική μορφή, σε διάφορες γλώσσες,
στην ιστοσελίδα www.gameready.com

מדריך זה למשתמש זמין באינטרנט במגוון שפות בכתובת www.gameready.com

Il presente Manuale d'uso si può trovare online in diverse lingue nel sito
www.gameready.com

本ユーザー・マニュアルは、www.gameready.comへ行けば様々な言語で
オンライン閲覧できます

본 사용 설명서는 www.gameready.com에서 온라인으로 다양한 언어로 제공됩니다

Niniejsza instrukcja obsługi jest dostępna online w różnych językach, na stronie
www.gameready.com

Este Manual do Usuário pode ser encontrado on-line em vários idiomas em
www.gameready.com

Эту инструкцию по эксплуатации на разных языках можно найти в сети Интернет
по адресу www.gameready.com

Den här användarhandboken finns online på flera språk på
www.gameready.com

Bu Kullanıcı El Kitabı çevrim içi olarak çeşitli dillerde www.gameready.com
adresinde bulunabilir

目录

Game Ready 介绍.....	2
详细的使用说明	4
操作模式.....	5
按钮	5
调节温度.....	6
显示.....	6
运行系统.....	8
储存	12
清洁	12
维护	14
配件	15
使用适应症.....	15
禁忌症.....	15
一般警告和注意事项	16
规格	17
UL分类.....	18
电磁兼容性.....	19
故障排除.....	24
保修	27
保修登记.....	28
注册人、代理人信息.....	29

GAME READY 介绍

Game Ready® (CoolSystems, Inc.) 总部设在加利福尼亚州康科德, 成立于 1997 年。是一个帮助运动员和患者从受伤或骨科手术中恢复的一流运动医学和骨科医疗器械公司。

有 ACCEL® 技术的 Game Ready 系统可为医疗服务提供商提供加速身体自然修复的动力, 并在损伤和术后恢复方面设置一个新标准。

由一个具有专有 ACCEL 技术 (主动加压和冷交换循环) 特色的加压冷疗系统和一个设计用于身体每一部分的全套双重作用包裹绷带组成, 这个革命性的系统是唯—集成主动加压和冷敷治疗, 以加速自然愈合。

遭受肌肉骨骼损伤后, 体内立即引发一系列保护周围组织的生理反应, 并开始修复损伤。而在这个过程, 炎症是一个自然和必需的机制, 如果有效控制它, 实际上可以让身体更快进入愈合的后期阶段。至今, RICE (休息-冰敷-加压-抬高) 原理已被用于被动控制症状、减轻疼痛和肿胀。

产品登记

请在 30 日内, 登录 www.gameready.com, 在线填写 GRPro® 2.1 加压冷疗系统与包裹绷带的保修登记表。包裹绷带登记卡与每个包裹绷带一起包装。其他保修信息可以在本手册的保修章节中找到。

不仅缓解症状, 帮助加速愈合

我们乐意收到您的信息。如果您有疑问、要了解更多信息或愿与大家分享使用 Game Ready 系统的经验, 请给我们打电话 1.888.426.3732 或给我们发送电子邮件到 info@gameready.com。

1.888.GameReady (1.888.426.3732)
www.gameready.com

注意事项: 美国联邦法律限定该器械要通过执业保健医师销售或订购。

警告: 关于使用频率和持续时间, 请听从您的保健医生的建议。GRPro 2.1 放置不当或延长使用时间, 可导致组织损伤。如果出现灼伤、瘙痒或疼痛和肿胀加重, 请立即停止继续使用。频繁监测皮肤接受冷疗, 如果发生比如水泡、红肿加重、变色或出现伤痕, 则立即停止继续使用。

重要: 在使用本产品之前, 请阅读全部适用证、禁忌证、小心和警告说明!



GRPRO® 2.1 系统的介绍

以下项目包含在您的 GRPro 2.1 系统中：

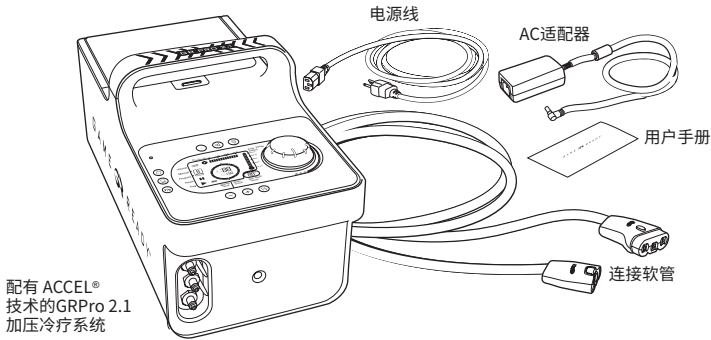

为了开始治疗, 包裹绷带 (由一个内部 ATX 系列热交换器和一个外套筒组成) 必须连接到系统上。

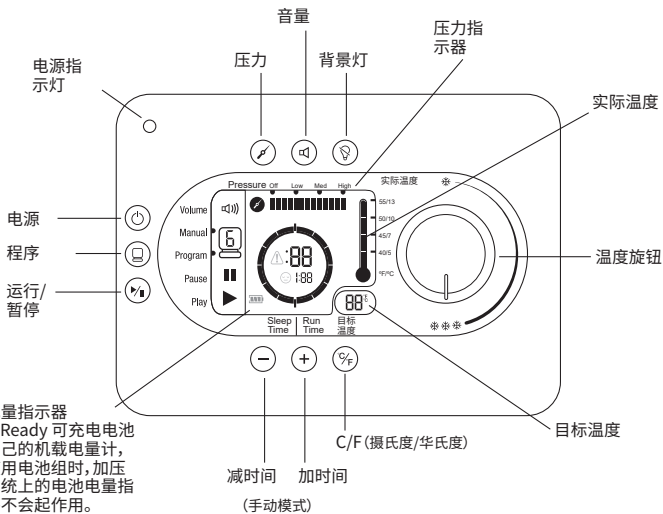
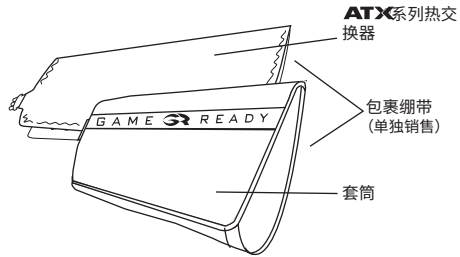

注: 如需安装、使用或维护系统方面的帮助, 或者要报告意外的操作或事件, 请联系客户服务中心 1.888.426.3732 (+1.510.868.2100), 若在美国以外地区, 请联系您当地的分销商。

	Game Ready 系统在电击、火灾和机械危险方面仅依据 EN 60601-1:2006 + A1:2013、IEC 60601-1:2012、IEC 60601-1-6:2010 (第三版) + A1:2013、IEC 60601-1-11:2010 和 ANSI/AAMI ES60601-1:2005(R)2012。
	直流电供电
	BF 型应用部件
	警告：在使用器械之前，请务必通读并理解使用说明。不遵守操作说明可能导致严重伤害。
	注意：参考使用说明
	制造商
	一个特定国家“制造”的符号(XXXX)
	一个特定国家“装配”的符号(XXXX)

详细的使用说明

在使用本器械之前，要求用户通读本用户手册。

在未得到医生关于治疗的频率和持续时间的具体建议之前，切勿使用本器械。

最常见的建议是使用冷疗每天至少 4 次，每次大约 30 分钟，每次治疗之间至少休息 30 分钟。

而温度是可调的，据报道，冷疗的最大益处是在 4.5-15.5°C 温度范围内。

在手术或受伤后前 24-48 小时期间，通常报道的加压建议是“无”(None)或“低”(Low)压力设置，只有当前 48 小时后感觉舒服，才能升高到“中”(Medium)或“高”(High)。

如果卧床，我们建议决不要施加“高”压力。

操作模式

手动模式 (Manual) :系统在这个模式下自动启动,允许用户调节治疗时间和压力设置。

程序模式 (Program) :这个模式允许用户从 6 个治疗方案中选择一个,即在一个特定压力设定下,在一个设置时间内给予治疗,然后在一个设置时间内睡眠(不给予治疗)的连续治疗方案。

排水模式 (Drain) :允许用户将带有专门软管接头(单独购买)的软管连接到加压冷疗系统上,进入排水模式,让加压冷疗系统将冰箱里的水通过软管排空。排水模式可以通过按下程序键进入,并可在所有 6 个程序之间切换。当在排水模式下进行系统排水时,按下程序键直到切换到排水模式,将软管接头连接到连接软管上,将软管接头放在水槽上方,按下运行按钮。排水模式将使加压冷疗系统的液体泵运行长达 6 分钟(长到足以完全排空冰箱)。排空模式用以下图标表示:



按钮















	电源(Power) :使用这个按钮可以开启和关闭加压冷疗系统。
	程序(Program) :使用这个按钮,从现有程序中选择一个或返回手动模式。欲了解程序的更多信息,请参见本手册的第 11 页。
	运行/暂停(Play/Pause) :使用这个按钮开启或暂停治疗。
	加时间(Add Time) :使用这个按钮在手动模式下增加时间(在程序模式下失灵)。可以增加多达 90 分钟。为了加或减时间,必须暂停治疗。
	减时间(Subtract Time) :使用这个按钮在手动模式下减时间(在程序模式下失灵)。可以减去多达 90 分钟。为了加或减时间,必须暂停治疗。
	压力选择(Pressure Selection) :使用这个按钮从 4 个压力设置中选择一个:无压力、低压(5-15 mmHg)、中压(5-50 mmHg)和高压(5-75 mmHg)。在程序模式下不能进行压力选择。变更压力设置时,必须暂停治疗。
	音量(Volume) :使用这个按钮选择声音或无声选项。按下以静音。即使关闭音量,警报仍然有声音。
	C/F 按钮 :使用这个键选择温度显示屏上的摄氏度或华氏度。
	背景光(Backlight) :使用这个按钮打开或关闭背景光。





温度调节

调节温度应用于治疗期间，简单将温度旋钮转向 3 个雪花（最大冷冻量），或转向 1 个雪花（最小冷冻量）。注意当您旋转旋钮时，屏幕上的“目标温度”(Target Temperature) 会发生改变。系统会自动调节与您选择的温度相匹配。

小提示：冷冻最大量由蓄水池中的冰量和温度调节旋钮的设置所决定。可能需要搅拌或补充冰以达到最冷温度。当 Game Ready 系统从治疗部位移走较多热量时，在损伤的急性期，冰会更快融化。

显示屏

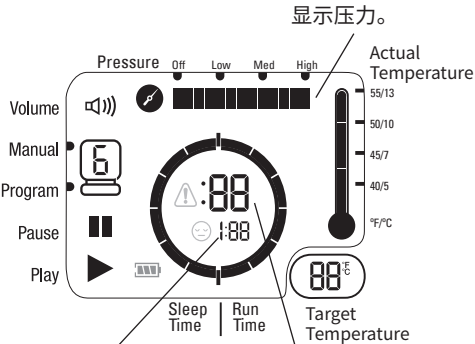
状态栏(Status bar): Vol 	Vol 	关闭(Off) (静音) 开启(On)
Manual  Program 	Manual  Program 	指示选择的模式。
Pause 	Pause 	指示单元暂停。
Play 	Play 	指示单元运行。
其他图标:	错误  睡眠  电池 	指示出现错误。错误代码见故障排除第 24-26 页。 指示睡眠模式时间。 指示剩余电池容量。
温度(Temperature) :	 	实际温度(Actual Temperature): 水离开加压冷疗系统的大约温度。 目标温度(Target Temperature): 指示目标温度设置。加压冷疗系统会自动与实际温度和目標温度尽可能近地匹配。

<p>当系统在程序模式下运行时:</p> <p>当系统在手动模式下运行时:</p>	 <p>睡眠时间倒计时栏。</p> <p>显示剩余的运行时间。</p> <p>运行时间倒计时栏。</p> <p>显示剩余的睡眠时间。</p>  <p>显示剩余的运行时间。</p>
<p>当选择一个程序时:</p> 	 <p>显示压力。</p> <p>显示单元即将睡眠的时间数量。</p> <p>显示单元即将运行的时间数量。</p>
<p>压力:</p> 	 <p>Off Low Med High</p> <p>Off Low Med High</p> <p>Off Low Med High</p> <p>Off Low Med High</p>

运行系统

要运行 GRPro 2.1 系统, 您需要:

- 按蓄水池填充线标指示, 用冰和水填充加压冷疗系统。首先加入 1.5 升水, 然后用冰填充到蓄水池的顶部以达到最佳性能。
- 电源。
- 连接软管。
- 包裹绷带 (包括热交换器和套筒)。

注:

- 包裹绷带由一个内部热交换器和外部套筒组成。套筒和热交换器的组合在整个手册中被称为“包裹绷带”。为了确保适当的性能, 一定要使用 ATX 系列热交换器。
- 使用期间, 应将加压冷疗系统放置在一个稳定的表面上 (比如地板或桌子)。
- 注意在环境温度较高的环境下使用该系统, 可能会影响其提供足够冷却的能力或可能限制冰的寿命。
- 如果将使用配有 Game Ready 可选电池组 (单独销售) 的系统, 请参阅电池组附带的使用说明。

警告:

- 操作之前, 若使用 FSP 电源, 则应将您的 GRPro 2.1 加压冷疗系统插入接地电源插座。若适用 Mega MDM-030-A120-5396 电源, 则不需要接地电源插座。
- 将加压冷疗系统置于最小风险被加压冷疗系统、连接软管或电源线绊倒的地方。

预防措施:

- 不能正确遵守本手册和那些您的医疗提供者的说明, 可能干扰或阻止提供正确治疗。
- 为了避免触电风险, 在用冰和水填充加压冷疗系统之前, 从电源插座拔下加压冷疗系统。

- 1 按下门释放开关打开冰箱门。

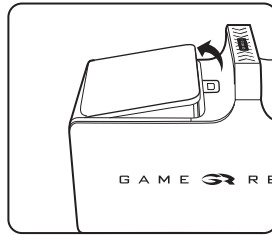
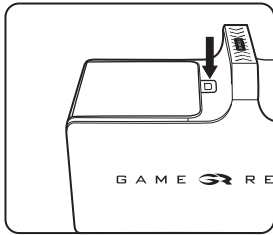

- 2 将水加到蓄水池填充线指示的标签位置。切勿装满。将冰加到蓄水池的顶部。

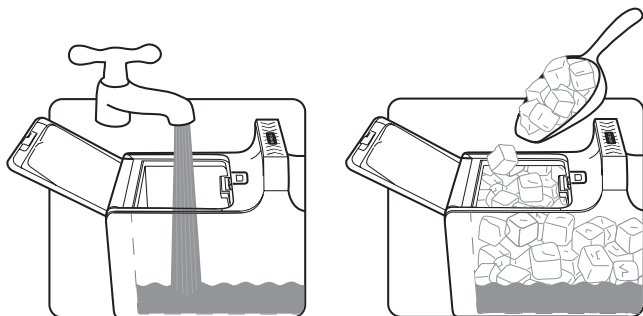

- 3 关上冰箱门。确保听到咔哒声。

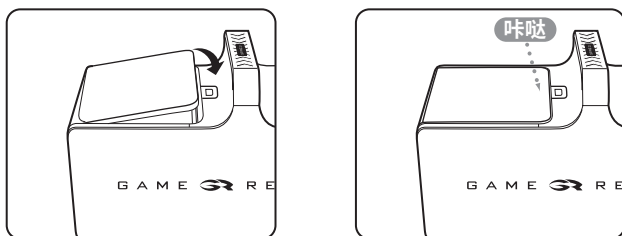

- 4 将加压冷疗系统置于您计划使用它的位置。加压冷疗系统应仅用于如图所示的向上方向。如果放在其侧面，加压冷疗系统会渗漏。

- 5 将 AC 适配器连接到加压冷疗系统终端配电板的插座上，然后将 AC 适配器插入电源插座。加压冷疗系统上的电源指示灯(橙色)应点亮。按下电源按钮(⊙)屏幕应点亮和加压冷疗系统应鸣响两次。电源指示灯应从橙色转换成绿色。如果未看到这些指示灯，请参阅本手册第 26 页的故障排除指南中的“加压冷疗系统无法打开”。

注：连接包裹绷带之前，应打开加压冷疗系统。

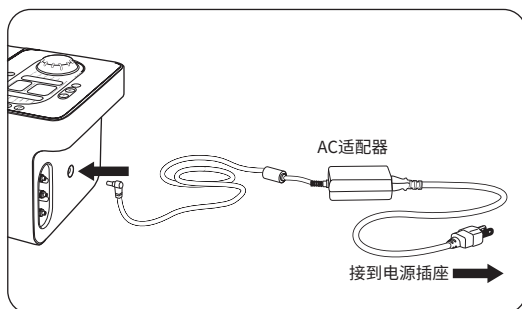

- 6 将连接软管的较大端(带有红色按钮)连接到加压冷疗系统上。确保听到“咔哒”声。要断开,只要简单按下红色按钮将连接器从加压冷疗系统拔下。

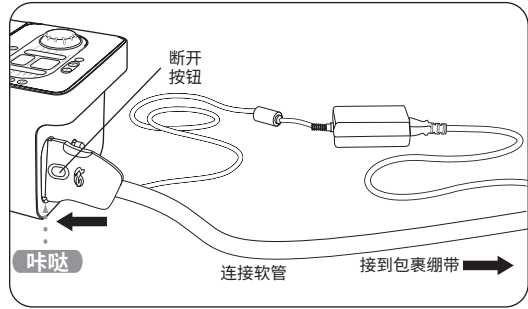

- 7 应用所选择的包裹绷带(应用说明请参阅每个包裹绷带附带的使用指南)。为了确保系统的适当性能,重要的是使用您包裹绷带中的 ATX 系列热交换器。

注意事项:

- 包裹绷带不是无菌。切勿直接对着开放性伤口、溃疡、皮疹、感染或拆线放置。包裹绷带可施加在衣服或敷料上面。
- 为了确保最佳合身,一定要在每次应用之前,将包裹绷带彻底排气。

- 8 将连接软管的较小端(带有蓝色或灰色按钮)连接到包裹绷带上。确保听到咔哒声。要断开连接,只是简单地按下蓝色或灰色按钮将连接器从包裹绷带上拔下。

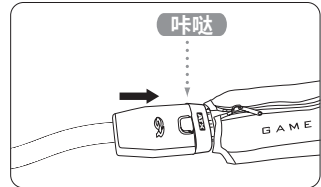
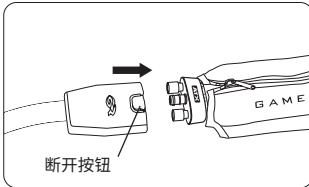



如果你对 GRPro 2.1 系统设置有任何疑问,美国的客户,请拨打 Game Ready 客户服务电话:1.888.426.3732 (+1.510.868.2100);美国以外的客户,请联系你的当地经销商。

警告:



- 遵循您的保健医生的治疗建议使用该器械。
- 不合适的位置或长时间使用 GRPro 2.1, 可导致组织损伤。
- 在使用本产品之前,请阅读全部适用证、禁忌证、小心和警告说明!

- 9 Manual ▶  选择操作模式。可以选择手动模式或程序模式。手动模式允许定制时间和压力设置。程序模式允许从 6 个自动程序中选择，即在一个特定压力设定下 (参阅以下可以程序表)，在一个设置的时间间隔内给予治疗，然后在一个设置时间内“睡眠” (不给予治疗) 的连续治疗方案。加压冷疗系统自动启动在手动模式下。

手动模式：

 	按+/-按钮，以 5 分钟增加数设置时间。
	按下压力按钮，设置压力。你可以从 4 个压力设置中选择：无压力、低压 (5-15 mmHg)、中压 (5-50 mmHg) 和高压 (5-75 mmHg)。

程序模式：

	按下程序按钮，进入程序模式。在程序模式下，加压冷疗系统将按照选择的程序继续运行。如第 2 步先前所示，需要补充冰和水。
	<p>可以从以下程序中选择：(按下程序按钮，滚动可用程序)</p> <p>程序 1: 运行 30 分钟，睡眠 30 分钟。无压力。</p> <p>程序 2: 运行 30 分钟，睡眠 30 分钟。低压。</p> <p>程序 3: 运行 30 分钟，睡眠 30 分钟。中压。</p> <p>程序 4: 运行 30 分钟，睡眠 60 分钟。无压力。</p> <p>程序 5: 运行 30 分钟，睡眠 60 分钟。低压。</p> <p>程序 6: 运行 30 分钟，睡眠 60 分钟。中压。</p> <p>程序 d: 排水 模式。详细介绍，请参阅本手册的第 5 页。</p>

- 10  按下运行/暂停键，启动有 ACCEL 技术的 Game Ready 治疗。可随时按下运行/暂停键，停止治疗。

- 11 转动旋钮，设置目标温度 (显示在目标温度窗口)。对于最冷治疗，顺时针转动旋钮朝向 3 个雪花位置。对于较暖治疗，逆时针转动旋钮朝向 1 个雪花位置。

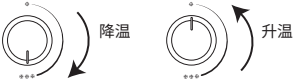

- 12 如第 2 步所示，按需补充冰和水水位，保持目标温度。

- 13 使用后，
- 从加压冷疗系统拔下 AC 适配器和连接软管
 - 按下门释放开关打开门
 - 小心地倒出冰和水
 - 擦干任何多余的水

储存

当天用完系统时:

- 从加压冷疗系统拔下 AC 适配器和连接软管。
- 按下门释放开关打开门。
- 小心地倒出冰和水。
- 擦干干净任何多余的水。
- 加压冷疗系统以其盖完全打开允许内部干燥并保持蓄水池密封的方式储存。将加压冷疗系统储存在携带袋或其他安全的地方。请记住, GRPro 2.1 加压冷疗系统是一种贵重的器械, 要像一台笔记本电脑一样小心对待。

储存的温度条件: 1° - 50°C

相对湿度: 10% - 95% 不冷凝

注意事项:切勿在极端冷或热的温度 (1°C 以下或 50°C 以上) 环境下保存。切勿留在炎热或冷冻的车里。切勿将加压冷疗系统直接在日光下直射。紫外线可使加压冷疗系统损坏或变色。

清洁

系统

如果需要, 可用异丙醇和水的混合液冲洗系统 (加压冷疗系统、软管和包裹绷带), 并不加压 (“关”) 运行。此后仅在无压力 (“关”) 设置下, 用清洁水运行加压冷疗系统。

加压冷疗系统

加压冷疗系统的外部 and 蓄水池的看得见的内表面, 可以用软布和以下清洁剂的一种进行清洁:

- 温和清洁剂
- 70% 异丙醇
- Antifect® FF
- Mikrozyd® 敏感湿巾
- 季铵盐 (比如 Virex® – 通常只有在临床使用环境中看到)
- Cavicide®

步骤:

- 遵守所选清洁剂制造商的使用说明和注意事项。
- 将所选清洁剂涂在软布上, 擦拭干净加压冷疗系统的所有表面。
- 在将其储存于袋之前, 让加压冷疗系统彻底干燥。
- 加压冷疗系统应按需清洁。

切勿使用:

- 酚醛基消毒剂 (比如 Amphyl® – 通常只在临床使用环境中看到)。
- 任何溶剂基清洁剂用于加压冷疗系统。如果这样做会损坏塑料, 则将导致保修失效。
- 用研磨材料清洁加压冷疗系统。如果这样做会损坏塑料, 则将导致保修失效。

注意事项:本加压冷疗系统不是防水器械。切勿将任何液体流直接喷向加压冷疗系统, 淹没加压冷疗系统, 或让任何液体在加压冷疗系统的前部面板的表面上形成一滩水。

连接软管

连接软管的表面,可以用软布和以下清洁剂中的一种清洁:

- 温和清洁剂
- Steri-Fab®
- Antifect® FF
- Mikrozid® 敏感湿巾
- 70% 异丙醇
- 我们不建议使用季铵盐(比如 Virex®)或 Cavicide®。

切勿使用:

- 酚醛基消毒剂(比如 Amphyl® - 通常只在临床使用环境中看到)。
- 任何溶剂基清洁剂。如果这样做会损坏塑料,则将导致保修失效。
- 研磨材料。如果这样做会损坏塑料,则将导致保修失效。
- 任何石油基润滑剂。这样做会损坏 O 形圈,并会导致保修失效。如果需要润滑,建议使用硅喷剂。

包裹绷带

将热交换器轻轻地从套筒中取出。利用温和清洁剂或抗菌肥皂,在冷水中手洗套筒。切勿使用织物柔软剂。悬挂干燥。

如需要,热交换器的外表面可以使用市售非漂白清洁湿巾。擦拭干净,或使用少量温和清洁剂或抗菌肥皂手洗。切勿机洗。

更多信息,请参阅单个包裹绷带附带的包裹绷带使用指南。

携带袋

携带袋应使用软布或软刷和温和清洁剂清洁。如果需要的话,携带袋可以使用 Febreze®或等效物。如果携带袋的表面上有生物物质,则可以使用 Steri-Fab® 净化这些表面。

一定要在袋的一小部分上测试任一产品,确保它不会引起损坏。

注:要操作 GRPro 2.1 系统,不需要将其从携带袋中取出。只需拉开携带袋的主要组件和终端配电板。将蓄水池装满冰和水。将连接软管和 AC 适配器连接到加压冷疗系统的终端配电板上,并将 AC 适配器插入电源插座。

应根据需要, 检查、清洁和/或更换蓄水池过滤器。

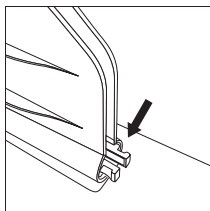

1 鉴定蓄水池中的过滤器。

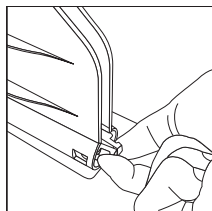

2 用两个手指, 抓住并挤压两只突出尖头叉子。

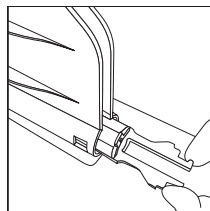

3 将过滤器拉出。

4 将过滤器中的碎片冲洗掉, 确保没有明显的损坏迹象。

如果您有任何疑问或想订购一台新的过滤器, 美国的客户, 请拨打 Game Ready 客户服务电话: 1.888.426.3732 (+1.510.868.2100); 美国以外的客户, 请联系您的当地经销商。

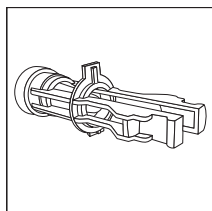

5 要更换或安装一个新的过滤器, 首先确保过滤器与塑料标签朝上面方向正确。如果过滤器的方向不正确, 则突出的标签会妨碍过滤器滑回原处。

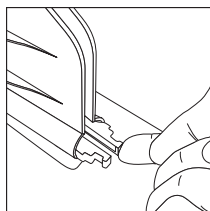

6 您会感觉到和听到过滤器弹回原处。

除了维护蓄水池过滤器外, 用户不应进行任何产品维修或改动。如果 GRPro 2.1 需要维修, 美国的客户, 请拨打 Game Ready 客户服务电话: 1.888.426.3732 (+1.510.868.2100); 美国以外的客户, 请联系您的当地经销商。

配件

GRPro 2.1 加压冷疗系统可以与以下任一配件一起使用：

- 使用 ATX 系列热交换器的任何 Game Ready 包裹绷带 (由任何其他制造商制造包裹绷带不能与本系统一起使用)
- Game Ready 提供的 Mega MDM-030-A120 电源
- Game Ready 提供的连接软管
- Game Ready 的携带袋
- Game Ready 的排水模式接头
- Game Ready 可充电电池组

如果需要长时间储存电池组，建议定期对电池进行充电以保持电池的电子完整性。在使用前和每六 (6) 个月完全充电。

适用范围

注意事项:美国联邦法律限定该器械要通过执业保健医师销售或订购。

- **本器械的使用持续时间和频率, 请听从您的保健医师的建议。**

该产品将冷疗和加压治疗联合起来, 用于术后和急性损伤治疗, 以缓解指示冷敷和加压治疗的水肿、肿胀和疼痛。

目的是由医院、门诊、运动员训练环境或家庭环境的执业保健专业人员使用或订购。

禁忌症

重要: 包裹绷带的具体禁忌症和警告, 请阅读包裹绷带用户手册。

利用 Game Ready 系统的加压治疗或任何加压治疗器械不得用于以下患者:

- 受影响区域处于炎症性静脉炎急性期的患者。
- 在受影响区域提示有深静脉血栓形成的任何目前临床症状的患者。
- 在受影响区域有明显的动脉硬化或其他血管缺血性疾病的患者。
- 有栓塞的任何显著危险因素或目前临床症状 (例如肺栓塞、脑梗塞、心房颤动、心内膜炎、心肌梗死或动脉粥样样栓塞斑块)。
- 在受影响的肢体中有不希望的静脉或淋巴回流加重 (比如, 癌) 情况的患者。
- 在受影响区域有压力过高的患者。
- 临床医师认为术后测试或控制治疗不妥的任何情况
- 使用 Game Ready® 设备不妥的任何情况
- 目前正在参与可能会影响结果的其他临床测试

利用 Game Ready 系统的冷疗或任何冷疗器械不得用于以下患者:

- 在受影响区域 (比如, 从先前冻伤、糖尿病、动脉硬化或局部缺血) 有明显血管损伤的患者。
- 有已知影响血栓形成的血液恶液质 (如阵发性冷性血红蛋白尿、冷球蛋白血症、镰状细胞病和血清冷凝集素) 的患者。

警告

- 本器械的使用持续时间和频率,请遵守您的保健执业医师的建议。
- Game Ready 系统放置不当或延长时间使用,可导致组织损伤。
- 在术后不久应格外小心,尤其当镇静或接收任何可改变正常疼痛感觉的药物时。频繁检查治疗部位的皮肤,并根据需要使用中-高(更暖)温度范围的设置或在两次治疗之间间隔更长时间。
- 所有患者在包裹绷带和皮肤之间铺一层布。
- 在治疗期间,患者应监视治疗区域、周围区域和治疗肢体末端(如适用)的皮肤的任何灼伤、瘙痒、肿胀加重或疼痛。如果存在这些症状中的任一症状,或皮肤外观发生任何变化(比如,水泡、红肿加重、变色或皮肤的其他明显变化),建议患者停止使用并咨询医生。
- Game Ready 包裹绷带不是无菌;切勿直接对着开放性伤口、溃疡、皮疹、感染或拆线放置。包裹绷带可施加在衣服或敷料上面。
- Game Ready 包裹绷带有多种配置可供选择,但并不适用于所有可能的生理用途。例如,脚踝包裹绷带不适用于脚趾,背部包裹绷带不适用于腹部区域。

用 Game Ready 系统加压治疗, 应在执业保健医师监督下用于以下患者:

- 在受影响区域有开放性伤口(使用 Game Ready 之前,必须包扎伤口)的患者。
- 在受影响区域有急性、不稳定性(未处理)骨折的患者。
- 18岁以下的儿童或有认知障碍或交流障碍,无论是暂时(由于药物)或临时的患者。
- 患有心功能不全或充血性心力衰竭(与四肢或肺水肿有关)的患者。
- 在受影响区域有局部不稳定的皮肤情况(例如,皮炎、静脉结扎术、坏疽或近期植皮)的患者。
- 在受影响的区域有丹毒或其他活动性感染。

用 Game Ready 系统冷疗, 应在执业保健医师监督下只用于以下患者:

- 患有雷诺氏病或冷超敏性(寒冷性荨麻疹)的患者。
- 患有高血压或极低血压的患者。
- 患有糖尿病的患者。
- 在受影响区域的局部循环受累或神经功能损伤(包括麻痹或由于多次手术的局部受损)的患者。
- 在受影响区域有局部不稳定的皮肤情况(例如,皮炎、静脉结扎术、坏疽或近期植皮)的患者。
- 在受影响区域患有类风湿性关节炎的患者。
- 18岁以下的儿童或有认知障碍或交流障碍,无论是暂时性(由于药物)或永久性的患者。



警告:为了符合《加州 65 号法案》规定,已包括下列警告。本产品可能会使您接触到化学物质,包括镉、铬、铅、多溴联苯或汞,加利福尼亚州已知这些化学物质会导致癌症或生殖毒性。欲知详情,请访问www.prop65warnings.ca.gov。

注意事项

- 为了避免触电危险，切勿将任何配电板从加压冷疗系统中取出。打开箱子会导致 Game Ready 的保修失效。对于所有服务和维修，美国的客户，请拨打 Game Ready 客户服务电话：1.888.426.3732 (+1.510.868.2100)；美国以外的客户，请联系您的当地经销商。
- 为了避免触电危险，当不使用，或添加或清空冰和水前，要始终关闭系统和将电源线从电源插座拔出。
- 切勿使用不是由 Game Ready 提供的任何 AC 适配器。使用其他适配器可导致触电，并会导致 Game Ready 保修失效。
- 为了避免损坏您的产品，切勿在冰箱中没有水的情况下操作系统。
- 为了避免触电、产品故障或损坏，在电源线或连接软管损坏，或其他机械损坏，或如果加压冷疗系统在其他方面不能全面运行的情况下，决不操作该系统。
- 为了避免对您产品的潜在损坏，切勿向冰箱中倾倒热水。系统不适用于用热水操作，未用热水进行过测试。
- 冰箱中除了的冰和水外，切勿使用任何东西。
- 为了避免对产品的损坏，切勿拿起加压冷疗系统的盖子。仅限使用把手携带加压冷疗系统。
- 为了避免对产品的潜在损坏，切勿使用其他制造商的包裹捆绑于 Game Ready 系统。
- 为了避免对产品的损坏，在没有接入连接软管的条件下，切勿操作加压冷疗系统。
- 为了避免受伤，小心不要被系统的电源线和连接软管绊倒。
- 监测正在使用的软管和线缆的放置。存储不使用的软管和线缆，以避免缠绕窒息的可能。
- 使系统（包括软管和线缆）远离儿童和宠物。
- 处理小部件时应谨慎，以减少吞咽或吸入的可能。
- GRPro 2.1 加压冷疗系统是一个技术医疗器械。为了避免损坏您的产品，要像操作笔记本电脑一样小心操作它。切勿掉落它、踢它或不必要的其他方式滥用它。此类滥用会导致所有 Game Ready 保修失效。切勿将 AC 适配器或电池组装入冰箱内储存或运输。



- 加压冷疗系统上的这个符号或其包装意味着，该产品不得与您的家庭垃圾一起处置。要了解在哪丢弃您的电气和电子垃圾，请联系您的当地城市垃圾处置服务办公室或联系 Game Ready 寻求援助。
- 包裹捆绑没有特殊处置要求。

规格

尺寸：413 mm 长 x 197 mm 宽 x 235 mm 高，不包括携带袋。

重量：排空时为 3.3 kg，装满冰和水约为 8.2 kg

压力水平：周期从 5 mm Hg 达到 75 mm Hg

AC 电源：220 V~，50 Hz，1.6 A

DC 输入：12 V/2.5 A

- 器械的最大操作温度介于 1-40°C。
- 器械的最大工作高度为 3,000 米 (9,843 英尺)。
- 加压冷疗系统的预期使用寿命为 5 年。加压冷疗系统附带的零件和配件的预期使用寿命为 2 年。

UL分类

防触电保护：

当与MDM-030-A120/ATM-030-A120电源连接时，GR Pro 2.1系统归为II类。

MDM-030-A120 电源适合家庭使用。

防有害进水保护：

该产品可提供普通的防有害进水保护。当使用MDM-030-A120电源供应器械时，被归类为IP22类，其防止滴水。

污染度分类：

该产品被归类为2级污染度。

在有易燃麻醉剂或氧气存在时的安全度：

不适合在富氧环境或存在易燃麻醉剂的条件上使用。

电磁干扰：

已对该器械进行了测试，发现其符合IEC 60601-1-2:2007和IEC 60601-1-2:2014有关医疗器械的限制。这些限制旨在提供典型医疗安装中的合理防止有害干扰的保护。

该器械可产生、使用和辐射无线电频率能量，如果不按照使用说明安装和使用，可能对附近的其它器械产生有害干扰。然而，不能保证干扰不会发生在一个特定安装中。

如果该器械确实对其他器械会引起有害干扰，可通过开关器械进行确定，鼓励用户通过一个或多个以下措施尝试修正干扰：

- 重新调整或重新安装接收器械。
- 加大器械之间的间隔。将器械连接到与其他器械连接不同电路的插座上。
- 咨询制造商或区域服务技术人员寻求帮助。

该器械适用于骨科中心、治疗诊所、体育训练场馆、医院、护理机构、医疗中心以及患者的家中。该器械不得用于电磁干扰强度高的环境。

如果该器械由于电磁干扰而出现性能降低或受损，则该器械预计可继续安全操作。

该器械不得在距离任何便携式和移动式射频通信设备小于30 cm (12英寸)处使用。

电磁兼容性

已对该器械进行了测试,发现其符合 IEC 60601-1-2:2007 和 IEC 60601-1-2:2014 有关医疗器械的限制。这些限制旨在提供典型医疗安装中的合理防止有害干扰的保护。

该器械可产生、使用和辐射无线电频率能量,如果不按照使用说明安装和使用,可能对附近

的其它器械产生有害干扰。然而,不能保证干扰不会发生在一个特定安装中。

如果该器械确实对其他器械会引起有害干扰,可通过开关器械进行确定,鼓励用户通过一个

或多个以下措施尝试修正干扰:

- 重新调整或重新安装接收器械。
- 加大器械之间的间隔。将器械连接到与其他器械连接不同电路的插座上。
- 咨询制造商或区域服务技术人员寻求帮助。

该器械适合用于骨科中心、治疗诊所、体育训练场馆、医院、护理机构、医疗中心以及患者的家中。该器械不得用于电磁干扰强度高的环境。

如果该器械由于电磁干扰而出现性能降低或受损,则该器械预计可继续安全操作。

该器械不得在距离任何便携式和移动式射频通信设备小于 30 cm (12 英寸) 处使用。

医用电气设备需要有关电磁兼容性的专门提示,以及根据随机文件提供的电磁兼容性信息进行安装和使用的说明;

便携式和移动式射频通信设备可能影响医用电气设备的说明。

警示:

除设备或系统的制造商作为内部元器件的备件出售的电缆外,使用规定外的附件和电缆可能导致设备或系统发射的增加或抗扰度的降低。

序号	名称	制造商	型号或编号	是否屏蔽	长度(M)
1	加压冷疗系统适配器线	Mega/Adapter Tech	ATM-030-120 MDM-030-A120	是	1.5
2	加压冷疗系统电源线	东莞维升电子制品有限公司	WS-004B	是	2.0
3	电池电源线	东莞维升电子制品有限公司	WS-004B	是	2.0
4	电池组充电器线	CoolSystems, Inc.	303677	是	1.5
5	电池连接线缆	YONGHAO	300V VW-1	是	0.9

设备或系统不应与其他设备接近或叠放使用,如果必须接近或叠放使用,则应观察验证在其使用的配置下能正常运行。

产品基本性能的功能:

压力控制

有4个档设置压力:1) 无压力;2) 低压力:压力值在5mmHg~15mmHg范围内,误差不超过10mmHg;3) 中压:压力值在5mmHg~50mmHg范围内,误差不超过10mmHg;4) 高压:压力值在5mmHg~75mmHg范围内,误差不超过10mmHg。

辐射表 1

指南和制造商的声明——电磁发射		
GR PRO 2.1加压冷疗系统机/303677电池组充电器预期在下列规定的电磁环境中使用, 购买者或使用者应保证它在这种电磁环境下使用		
发射试验	符合性	电磁环境——指南
射频发射 GB4824	1组	GR PRO 2.1加压冷疗系统机/303677电池组充电器仅为其内部功能而使用射频能量。因此, 它的射频发射很低, 并且对附近电子设备产生干扰的可能性很小。
射频发射 GB4824	B类	GR PRO 2.1加压冷疗系统机/303677电池组充电器适于使用在所有设施中, 包括家用和与直接连接到供家用的住宅公共低压供电网。
谐波发射 GB17625.1	A类	
电压波动/闪烁发射GB17625.2	适用	

(对应于YY0505-2012中表201)

瞬变电磁抗扰度表 2

指南和制造商的声明——电磁抗扰度			
GR PRO 2.1加压冷疗系统机/303677电池组预期在下列规定的电磁环境中使用, 购买者或使用者应保证它在这种电磁环境中使用			
抗扰度试验	IEC60601试验电平	符合电平	电磁环境——指南
静电放电 GB/T 17626.2	±6 kV接触放电 ±8 kV空气放电	±6 kV接触放电 ±8 kV空气放电	地面应是木质、混凝土或瓷砖。如果地面用合成材料覆盖, 则相对湿度应至少30%
电快速瞬变脉冲群 GB/T 17626.4	±2 kV对电源线 ±1kV对输入/输出线	±2 kV对电源线 不适用	网电源应具有典型的商业或医院环境中使用的质量
浪涌 GB/T 17626.5	±1 kV线对线 ±2 kV线对地	±1 kV线对线 不适用	网电源应具有典型的商业或医院环境中使用的质量
电源输入线上电压 暂降、短时中断和 电压变化 GB/T 17626.11	<5% U_T , 持续 0.5周期 (在 U_T 上, >95% 的暂降) 40% U_T , 持续5 周期 (在 U_T 上, 60%的 暂降) 70 U_T , 持续25 周期 (在 U_T 上, 30%的 暂降) <5% U_T , 持续5s (在 U_T 上, >95% 的暂降)	<5% U_T , 持续 0.5周期 (在 U_T 上, >95% 的暂降) 40% U_T , 持续5 周期 (在 U_T 上, 60%的 暂降) 70 U_T , 持续25 周期 (在 U_T 上, 30%的 暂降) <5% U_T , 持续5s (在 U_T 上, >95% 的暂降)	网电源应具有典型的商业或医院环境中使用的质量。如果GR PRO 2.1加压冷疗系统机/303677电池组充电器的用户在电源中断期间需要连续运行, 则推荐GR PRO 2.1加压冷疗系统机/303677电池组充电器采用不间断电源或电池供电
工频磁场 (50/60Hz) GB/T 17626.8	3 A/m	3 A/m	工频磁场应具有在典型的商业或医院环境中典型场所的工频磁场水平特性
注: U_T 指施加试验电压前的交流网电压。			

RF电磁抗干扰性表 3

(对应于YY0505-2012中表202) 指南和制造商的声明——电磁抗扰度			
GR PRO 2.1加压冷疗系统机/303677电池组充电器预期在下列规定的电磁环境中使用,购买者或使用者应保证它在这种电磁环境中使用			
抗扰度试验	IEC60601试验电平	符合电平	电磁环境——指南
射频传导 GB/17626.6 射频辐射 GB/17626.3	3V(有效值) 150kHz~80MHz 3V/m 80MHz~1GHz	3V(有效值) 3V/m	便携式和移动式射频通信设备不应比推荐的隔离距离更靠近GR PRO 2.1加压冷疗系统机/303677电池组充电器的任何部分使用,包括电缆。该距离应由与发射机频率相应的公式计算。 建议的间隔距离 $d = 1.2 \sqrt{P}$ $d = 2.3 \sqrt{P}$ 800 MHz - 2.5 GHz 式中: P——根据发射机制造商提供的发射机最大额定输出功率,以瓦特(W)为单位; d——推荐的隔离距离,以米(m)为单位。 固定式射频发射机的场强通过对电磁场勘测a来确定,在每个频率范围b都应比符合电平低。 在标志下列符号的设备附近可能出现干扰 
注1:在80 MHz和800 MHz频率点上,采用较高频段的公式。 注2:这些指南可能不适合所有的情况,电磁传播受建筑物、物体及人体的吸收和发射的影响。			
^a 固定式发射机,诸如:无线(蜂窝/无绳)电话和地面移动式无线电的基站、业余无线电、调幅和调频无线电广播以及电视广播等,其场强在理论上都不能准确预知。为评定固定式射频发射机的电磁环境,应考虑电磁场所的勘测。如果测得GR PRO 2.1加压冷疗系统机/303677电池组充电器所处场所的场强高于上述适用的射频符合电平,则应观测GR PRO 2.1加压冷疗系统机/303677电池组充电器以验证其能正常运行。如果观测到不正常性能,则补充措施可能是必需的,比如重新调整GR PRO 2.1加压冷疗系统机/303677电池组充电器的方向或位置。 ^b 在150kHz~80MHz整个频率范围,场强应低于3V/m。			

(对应于YY0505-2012中表204)

RF抗干扰能力表 4

便携式及移动式射频通信设备和GR PRO 2.1加压冷疗系统机/303677电池组的推荐隔离距离

GR PRO 2.1加压冷疗系统机/303677电池组充电器预期在辐射骚扰受控的电磁环境中使用。依据通信设备最大额定输出功率，GR PRO 2.1加压冷疗系统机/303677电池组充电器购买者或使用者可通过下面推荐的维持便携式及移动式射频通信设备(发射机)和GR PRO 2.1加压冷疗系统机/303677电池组充电器之间最小距离来防止电磁干扰

发射机的最大额定输出功率W	对应发射机不同频率的隔离距离/M		
	150 KHZ - 80 MHZ $d = 1.2 \sqrt{P}$	80 MHZ - 800 MHZ $d = 1.2 \sqrt{P}$	800 MHZ - 2.5 GHZ $d = 2.3 \sqrt{P}$
0.01	0.12	0.12	0.23
0.1	0.38	0.38	0.73
1	1.2	1.2	2.3
10	3.8	3.8	7.3
100	12	12	23

对于上表未列出的发射机最大额定输出功率，推荐隔离距离d，以米(m)为单位，可用相应发射机频率栏中的公式来确定，这里P是由发射机制造商提供的发射机最大额定输出功率，以瓦特(W)为单位。

注1:在80MHz和800MHz频率点上，应采用较高频范围的公式。

注2:这些指南可能不适合所有的情况，电磁传播受建筑物、物体及人体的吸收和反射的影响。

(对应于YY0505-2012中表206)

警告: GRPro 2.1 系统的基本性能为:

气动压缩循环:

高:5-75 mm Hg 循环

中:5-50 mm Hg 循环

低:5-15 mm Hg 循环

无压力:包裹绷带应向着大气通风。

气压准确度: ± 10 mm Hg

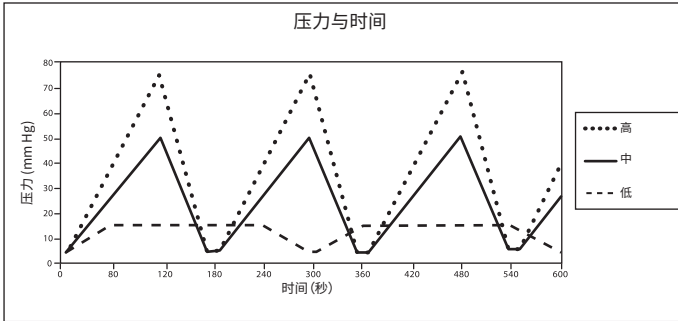

只要用足够的冰量供应冰箱中的冰水, 则循环冰水的冷却温度将会在 1°C 和 10°C 之间可调节。



水温准确度: $\pm 2.2^{\circ}\text{C}$

故障排除

错误	这是什么意思？	我能做什么？
 01	空气压力传感器: 加压冷疗系统已检测到一个在启动时校准空气压力回路的问题。	<ul style="list-style-type: none"> • 如果您已经重启了附带充气包裹绷带的系统，这是最有可能发生的。 • 拆下包裹绷带，将其压平排出内部累积的空气，然后再试一次。
 02	自检错误-气泵: 加压冷疗系统在启动时，已检测到空气回路中电子问题。	<ul style="list-style-type: none"> • 将包裹绷带从加压冷疗系统中断开。 • 在没有包裹绷带连接的情况下，再次开关加压冷疗系统。 • 再次将包裹绷带连接上，恢复治疗。 • 如果仍然存在问题，立即联系客服服务。
 04	干燥泵: 加压冷疗系统已检测到了干燥泵。为了防止可能的流体泵损坏，加压冷疗系统将停止治疗。	<ul style="list-style-type: none"> • 确保您正在使用 ATX 系列热交换器。 • 注: 如果您正在使用新包裹绷带，则蓄水池中的水可能已耗尽并导致该错误。根据填充线指示标签，确保蓄水池中有足够的水。请参阅以下包裹绷带的填充说明。 • 验证冰箱过滤器没有阻塞 (参阅第 14 页的过滤器维护说明)。 • 确保包裹绷带或连接软管中没有纽结。 • 再次关闭和打开加压冷疗系统。 • 将软管从加压冷疗系统和包裹绷带断开并重新连接，验证在两个连接点听见“咔哒”声音。 • 采用以下步骤填充包裹绷带。 <ul style="list-style-type: none"> - 选择“关”(无压力)。 - 将软管连接到加压冷疗系统和包裹绷带。 - 将包裹绷带躺着打开，并与加压冷疗系统齐平或低于加压冷疗系统 (不是在身体上)。 - 让系统运行 2 分钟。 • 使用以下步骤准备加压冷疗系统: <ul style="list-style-type: none"> - 将软管从加压冷疗系统拆下。 - 现在，看着包裹绷带在加压冷疗系统上的连接位置。在顶部阀门上，按下白色尖头叉子以便让其与金属接头齐平。 - 确保您没有完全盖住尖头叉子的开口。 - 按下启动键，水应从阀门喷出。 - 重启系统。
 06	超压: 指示加压冷疗系统已经超过了目标气压。	<ul style="list-style-type: none"> • 关闭加压冷疗系统，然后再打开。 • 确保包裹绷带连接牢固。 • 在治疗期间，切勿突然移动。在原位快速移动，包裹绷带上的压力可产生一个快速变化从而导致此错误。

错误	这是什么意思?	我能做什么?
 07	在压力之下: 加压冷疗系统无法达到其目标最大压缩。这常常表明气动压缩电路有泄漏, 或者在连接软管、包裹绷带或者加压冷疗系统。或者可能因为包裹绷带上的钩和环紧固件已经磨损而导致发生。	<ul style="list-style-type: none"> • 确保包裹绷带连接牢固。 • 尝试使用不同的包裹绷带和软管隔离可能产生错误的组件。例如, 一个错误发生在肩部包裹绷带而不是膝部包裹绷带, 可表明肩部包裹绷带引起错误; 而不是加压冷疗系统。 • 如果使用一个双软管, 确保已连接了两个包裹绷带。
 08	放气错误: 加压冷疗系统已检测出包裹绷带没有正常放气。	<ul style="list-style-type: none"> • 关闭加压冷疗系统。 • 如果包裹绷带中残留空气, 将包裹绷带从连接软管上拆下, 通过给它施加压力手动放气。 • 将软管重新连接到包裹绷带上, 重新将包裹绷带应用到身体上。 • 打开加压冷疗系统, 并按下运行/暂停键。 • 确保包裹绷带对着身体牢固应用。 • 如果可能, 尝试使用不同的包裹绷带和软管隔离可能产生错误的组件。例如, 一个错误发生在肩部包裹绷带而不是膝部包裹绷带, 可表明肩部包裹绷带引起错误; 而不是膝部包裹绷带或加压冷疗系统。
 09	泵的性能错误: 加压冷疗系统已确定流体泵可能运行太困难。这可能由流体回路的冰或碎片引起。为了防止可能的流体泵损坏, 加压冷疗系统将停止治疗。	<ul style="list-style-type: none"> • 关闭加压冷疗系统, 然后重新打开。 • 重新应用包裹绷带, 确保遵守包裹绷带附带的所有应用使用说明。 • 将软管从加压冷疗系统和包裹绷带断开并重新连接, 验证在两个连接点听到“咔哒”声。 • 如果没有解决这个问题, 将加压冷疗系统关闭 20 分钟 (让泵冷却下来), 然后重新开启再试一次。
 10	低流量: 加压冷疗系统已检测出水流中有东西堵塞。	<ul style="list-style-type: none"> • 确保您正在使用 ATX 系列热交换器。 • 检测全部软管连接。 • 将包裹绷带与连接软管断开和重新连接。 • 确保冰箱里有水。 • 核实冰箱过滤器没有被阻塞。 • 确保包裹绷带或连接软管中没有纽结。 • 重新舒适地应用包裹绷带, 确保遵守包裹绷带随附的所有应用使用说明。 • 再次关闭和打开加压冷疗系统。 • 将软管从加压冷疗系统和包裹绷带上断开和重新连接上。

有问题需要更多帮助吗? 美国的客户, 请拨打 Game Ready 客户服务电话 1.888.426.3732 (+1.510.868.2100); 美国以外的客户, 请联系您的当地经销商。

错误	这是什么意思?	我能做什么?
 	自测错误-流体回路: 加压冷疗系统已在启动时检测到流体回路中的一个电子问题。	<ul style="list-style-type: none"> • 关闭加压冷疗系统。 • 关闭加压冷疗系统, 然后打开, 并恢复治疗。 • 如果仍然存在问题, 立即联系客户服务。
 	温度校准错误: 加压冷疗系统已检测出温度控制回路有一个故障, 或在建议的温度范围 1-40°C 外运行。	<ul style="list-style-type: none"> • 确保您在建议的温度范围 1-40°C 内运行系统, 并在建议的温度范围 1-50°C 内储存系统。 • 关闭加压冷疗系统。 • 按照蓄水池里的标签指示, 向加压冷疗系统中填充冰和水。 • 关闭加压冷疗系统, 然后再次打开, 按下运行/暂停键。 • 重复这个过程最多三次。 • 如果仍然存在问题, 立即联系客户服务。
	加压冷疗系统无法打开:	<ul style="list-style-type: none"> • 按下电源按钮。如果橙色或绿色灯未点亮, 确保 AC 适配器插入工作电源插座, 并且所有连接都牢固。(用另一个电器器械测试插座。) • 再次按下电源按钮。如果加压冷疗系统仍然无法打开, 致电客户服务部。
	加压冷疗系统达不到目标温度, 或者温度不稳定:	蓄水池中的填充线标签显示的冰/水比值, 将协助加压冷疗系统达到已使用温度旋钮指定的温度。如果已按照填充线标签填充了加压冷疗系统后, 仍然无法达到所需目标温度, 请尝试以下步骤: <ul style="list-style-type: none"> • 如果仍然无法达到较暖(WARMER)温度, 确信温度旋钮转到满加热刻度, 使用少量的冰, 减少水量(如需要)。 • 如果仍无法达到较冷(COLDER)温度, 确信正在使用 ATX 系列热交换器。确认温度旋钮设置到满冷却刻度, 蓄水池装满冰, 频繁补充, 并搅动蓄水池打破大块冰(如需要)。确保包裹绷带或连接软管中没有扭结。重新应用包裹绷带, 确保遵守 附带的所有应用使用说明。最终, 如果仍然无法达到所需的最冷温度, 则添加比蓄水池填充线标签指示的水位更多的水, 也可以让加压冷疗系统达到 较冷温度。要达到这个效果, 可能要将水添加到冰位的顶部。注意事项: 如果按照 最后一步, 蓄水池装料过满, 系统的温度控制特征不会工作, 加压冷疗系统会在“满冷却”下给予治疗。查阅第 16 页的警告, 确保采取适当步骤将损伤危险降到最低。

保修

制造商的保修

CoolSystems 保证,在购买 GRPro 2.1 加压冷疗系统之日起两(2)年内,如果正确使用 GRPro 2.1 加压冷疗系统,在材料和工艺方面不会有缺陷。如果该有限保修的 GRPro 2.1 加压冷疗系统,在保修期间出现由该有限保修涵盖的原因所引发的故障,则在其选项中, CoolSystems 将:

- 修理 GRPro 2.1 加压冷疗系统,或
- 用另一个 GRPro 2.1 加压冷疗系统更换这个 GRPro 2.1 加压冷疗系统。

该有限保修和根据国家法律规定可能存在的任何默认保修,仅限适用于 GRPRO 2.1 加压冷疗系统的原始购买者,不得转让。

有限保修范围

该有限保修不涵盖由于外部原因引起的损坏,其中包括,但不限于,意外事故、不按照产品说明使用、滥用、疏忽、改造或修理。

如何得到保修服务

要得到保修服务,美国的客户,请拨打 Game Ready 客户服务电话:1.888.426.3732 (+1.510.868.2100);美国以外的客户,请联系您的当地经销商。如果您不确定当地经销商是谁,请拨打 Game Ready 客户服务电话+1.510.868.2100,我们会给您委托一个。从购买之日起30天内,您必须向CoolSystems 返回保修登记卡以获得保修资格。如果您从 CoolSystems 获取了保修服务资格,则会被签发一个退货材料授权 (RMA) 号码。当您把 GRPro 2.1 加压冷疗系统退回 CoolSystems 时,必须在包装外面写上 RMA 号码。如果包装上没有 RMA 号码,则 CoolSystems 将不会接受退回的 GRPro 2.1 加压冷疗系统。如果您将 GRPro 2.1 加压冷疗系统退回 CoolSystems,必须承担运输过程的损坏或损失风险。必须使用原始包装或等效包装。CoolSystems 可能要求书面核实您是 GRPro 2.1 加压冷疗系统的原始购买者。CoolSystems 可以选择用一个新的或修复产品更换或修理 GRPro 2.1 加压冷疗系统。收到后,退回产品应成为 CoolSystems 的财产。根据这个书面保证书,担保更换 GRPro 2.1 加压冷疗系统,并遵守相同限制,但不包括原保修期的剩余。本保证书不得转让。

保证限制和除外

这些保证取代所有其他明示或暗示的保证,包括,但不限于针对特定用途适销性的暗示保证。除这里规定外,COOLSYSTEMS 没有做出任何明示保证。COOLSYSTEMS 否认所有其他明示或暗示的保证,包括,但不限于针对特定用途适销性的暗示保证。某些司法管辖区不允许排除暗示保证,因此这种限制可能不适用于您。在限制的保修期有限期间内,所有明示或暗示的保证都是有限制的。保修期后,保证不可用。某些司法管辖区不允许限制暗示保证持续的期限,因此此限制可能不适用于您。

责任限制

根据本保证或任何其他明示或暗示保证的规定,如上所述 COOLSYSTEMS 的责任仅限于修理或更换。这些补救措施是违反保证的唯一和独有补救措施。COOLSYSTEMS 对直接、专门、附带,或对保证的任何违反所导致的后续损害,或根据任何其他法律理论,包括,但不限于,利润损失、停工、和损坏或更换器械和财产承担任何责任。某些司法管辖区不允许排除偶发或后续损害的排除或限制,因此上述限制或排除可能不适用于您。这个有限保证授予您特定权力,您还可以拥有因司法管辖区不同的其他权力。

保修登记

GRPro 2.1 的加压冷疗系统自购买之日起即具有 2 年保修期。热交换器、连接软管、AC 适配器和电源线有 1 年保修期。在制造商出现缺陷的情况下,包裹绷带套筒和套筒配件可以在购买后 7 日内退货。

登记

请于 30 日内,通过 www.gameready.com 网站,在线填写 GRPro 2.1 加压冷疗系统和包裹绷带的保修登记。填写保修登记,将需要以下信息:**加压冷疗系统的型号(REF)和序号(SN)**。这些号码位于加压冷疗系统底部的标签上。只需登录到 www.gameready.com,访问产品登记页,填写表格,并提交信息即可。

延期保修

GRPro 2.1 系统可以进行延期保修。要获取详细信息,美国的客户,请拨打 Game Ready 客户服务电话:1.888.426.3732 (+1.510.868.2100);美国以外的客户,请联系您的当地经销商。

涵盖 Game Ready 技术的现行专利清单可以在以下网站找到:
www.gameready.com/patents。

EC	REP
----	-----

EMERGO EUROPE
Prinsessegracht 20
2514 AP The Hague
荷兰

CE
2797

EMERGO AUSTRALIA
201 Sussex Street
Darling Park
Tower II, Level 20
Sydney NSW 2000
澳大利亚

产品附页

【产品型号】GRPRO 2.1

【生产日期】见标签

【失效日期】见标签

【注册人/生产企业】:冷疗系统公司 COOLSYSTEMS,INC.

【注册人住所】美国加利福尼亚州康科德市萨特尔大街1800号500室

(1800 SUTTER STREET SUITE 500 CONCORD CALIFORNIA 94520)

【生产地址】 10030 Foothills Blvd Roseville, CA USA 95747

【电话】+1.510.868.2100

【代理人/售后服务机构】爱诺生医疗器械(上海)有限公司

【代理人住所】上海市黄浦区湖滨路150号23楼(实际楼层20楼)2358室

【邮政编码】200021

【电话】021-80135186

【医疗器械注册证编号】国械注进20192010386

【产品技术要求编号】国械注进20192010386

【说明书修订日期】2022年7月21日

G A M E  R E A D Y[®]

 COOLSYSTEMS[®], INC.
DBA Game Ready[®]
1800 Sutter Street, Suite 500
Concord, CA 94520 USA
1.888.GAMEREDY +1.510.868.2100
www.gameready.com

G A M E  R E A D Y[®]

**GRPro[®] 2.1 CONTROL UNIT
User's Manual**

**MODEL NUMBERS
550550-03, 550550-03-RN, 550550-53**

This User's Manual can be found online in various languages at
www.gameready.com

دليل المستخدم هذا متوفر بلغات عدة على الموقع الإلكتروني
www.gameready.com

Dieses Betriebshandbuch ist in verschiedenen Sprachen online unter
www.gameready.com verfügbar

Este Manual del usuario está disponible en www.gameready.com en distintos idiomas

可前往在线获得本用户手册的多种语言版本
www.gameready.com

Denne brugervejledning kan findes online på forskellige sprog på www.gameready.com

Deze Gebruikershandleiding is online beschikbaar in verschillende talen op
www.gameready.com

Tämä käyttöopas löytyy netistä eri kielillä: www.gameready.com

On peut trouver ce manuel de l'utilisateur dans plusieurs langues en ligne à
www.gameready.com

Μπορείτε να βρείτε αυτό το Εγχειρίδιο Χρήσης σε ηλεκτρονική μορφή σε διάφορες γλώσσες
στη διεύθυνση: www.gameready.com

www.gameready.com ניתן למצוא את המדריך הזה למשתמש בשפות שונות באתר

Questo Manuale per l'utente è disponibile online in varie lingue su www.gameready.com

本ユーザー・マニュアルは、www.gameready.com
へ行けば様々な言語でオンライン閲覧できます。

www.gameready.com

에 가시면 이 사용자 설명서를 온라인에서 다양한 언어로 찾아보실 수 있습니다.

Niniejszą Instrukcję obsługi można znaleźć w internecie w różnych językach na stronie
www.gameready.com

Este Manual do Usuário pode ser encontrado online em vários idiomas em
www.gameready.com

Данную инструкцию по применению, а также ее переводы на различные языки,
можно найти на веб-сайте www.gameready.com

Denna användarhandbok finns tillgänglig på olika språk på nätet via
www.gameready.com

Bu Kullanıcı Kılavuzu, değişik dillerde çevrimiçi olarak www.gameready.com
adresinde bulunmaktadır

TABLE OF CONTENTS

Introduction to Game Ready.....	2
Detailed Instructions for Use	4
Modes of Operation	5
Buttons	5
Adjusting Temperature	6
Display.....	6
Operating the System	8
Storage	12
Cleaning.....	12
Maintenance.....	14
Accessories	15
Indications for Use.....	15
Contraindications.....	15
General Warnings and Cautions	16
Specifications.....	17
UL Classification	18
Electromagnetic Compatibility	19
Troubleshooting.....	24
Warranty	27
Warranty Registration.....	28

INTRODUCTION TO GAME READY

Based in Concord, California, and founded in 1997, Game Ready® (CoolSystems, Inc.) is a best-in-class sports medicine and orthopedic medical device that helps athletes and patients recover from injury or orthopedic surgery.

The Game Ready System with ACCEL® Technology gives healthcare providers the power to accelerate the body's natural repair mechanisms, setting a new standard in injury and post-op recovery.

Comprised of a control unit featuring proprietary ACCEL Technology (Active Compression and Cold Exchange Loop) and a complete range of dual-action Wraps designed for each body part, the revolutionary system uniquely integrates active compression and cold therapies to accelerate natural healing.

Immediately after suffering a musculoskeletal injury, the body initiates a series of physiological responses to defend surrounding tissues and begins to repair the damage. While inflammation is a natural and necessary mechanism in this process, controlling it effectively can actually allow the body to enter the later stages of healing faster. Until now, the RICE (Rest-Ice-Compression-Elevation) principles have been used to passively control symptoms, moderating pain and swelling.

REGISTER YOUR PRODUCT

Please complete your Warranty Registration within 30 days for both the GRPro® 2.1 Control Unit and the Wraps online at www.gameready.com. A Wrap registration card is packaged with each Wrap. Further warranty information can be found in the Warranty Section of this manual.

DON'T JUST TREAT SYMPTOMS, HELP ACCELERATE HEALING

We'd enjoy hearing from you. If you have questions, want to learn more, or wish to share your experience with the Game Ready System, please call us at 1.888.426.3732, or email us at info@gameready.com.

1.888.GameReady (1.888.426.3732)

www.gameready.com

CAUTION: United States Federal law restricts this device to sale by or on the order of a licensed healthcare practitioner.

WARNING: Follow the recommendations of your health care practitioner regarding the frequency and duration of use. Improper placement or prolonged use of the GRPro 2.1 could result in tissue damage. Discontinue use immediately if you experience burning, itching or increased pain and swelling. Monitor the skin receiving cold therapy frequently and discontinue use if changes such as blisters, increased redness, discoloration or welts occur.



IMPORTANT: READ COMPLETE INDICATIONS, CONTRAINDICATIONS, CAUTIONS AND WARNINGS BEFORE USING THIS PRODUCT!

DESCRIPTION OF THE GRPRO® 2.1 SYSTEM



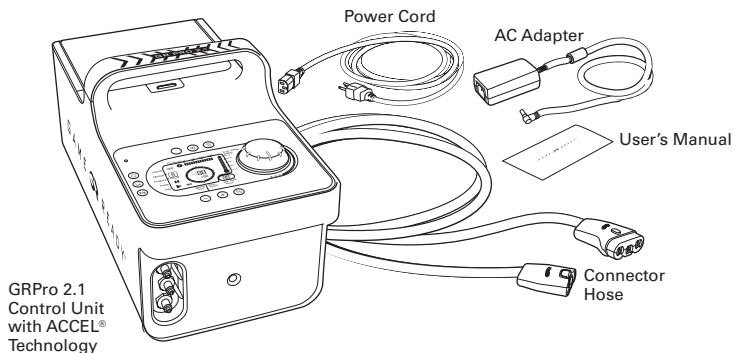

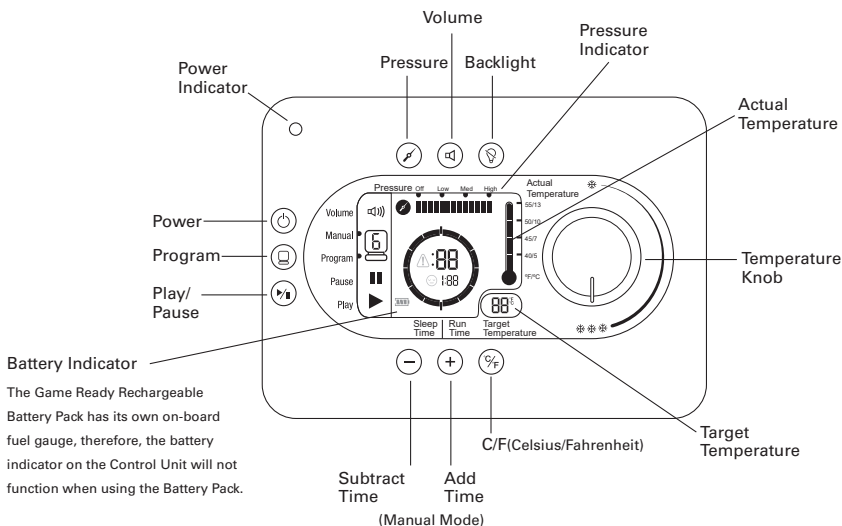
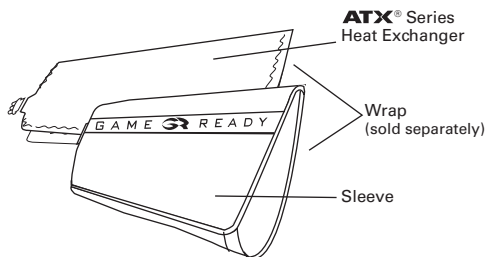

The following items are included in your GRPro 2.1 System:

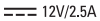

A Wrap (comprised of an inner ATX Series Heat Exchanger and an outer Sleeve) must be attached to the system to begin treatment. Each Wrap is sold separately and is not included in the system.



Note: For assistance setting up, using or maintaining the system, or to report unexpected operation or events, please contact Customer Service at 1.888.426.3732 (+1.510.868.2100), from outside of the U.S. please contact your local distributor.

	<p>Game Ready System as to electrical shock, fire and mechanical hazards only in accordance with EN 60601-1:2006 + A1:2013, IEC 60601-1:2012, IEC 60601-1-6:2010(3rd Ed.) + A1:2013, IEC 60601-1-11:2010 and ANSI/AAMI ES60601-1:2005(R)2012.</p>
	<p>Powered by Direct Current</p>
	<p>Type BF Applied Parts</p>
	<p>Warning: It is mandatory to fully read and understand the Instructions for Use before using the device. Failure to follow operating instructions could result in serious injury.</p>
	<p>Attention: Consult Instructions for Use</p>
	<p>Manufacturer</p>
	<p>Symbol for “made in” a specific country (XXXX)</p>
	<p>Symbol for “assembled in” a specific country (XXXXX)</p>

DETAILED INSTRUCTIONS FOR USE

Users are required to read this User’s Manual in full prior to using this device.

Do not use this device without your physician’s specific recommendations for the frequency and duration of your treatments.

The most common recommendation is to use cold therapy at least 4 times a day, for approximately 30 minutes each time, with at least a 30-minute break between treatments.

While the temperature is adjustable, it is reported that the greatest benefit from cold therapy is in the 40-60°F (4.5-15.5°C) temperature range.

Generally reported compression recommendations are for “None” to “Low” pressure settings during the first 24-48 hours after surgery or injury, increasing to “Medium” or “High” only if it is comfortable after the first 48 hours.

We recommend that “High” pressure is never applied if you are confined to bed.

MODES OF OPERATION

Manual Mode: The system automatically starts in this mode, and allows the user to adjust treatment time and pressure settings.

Program Mode: This mode allows the user to choose one of six treatment programs that provide therapy for a set time then sleep (no treatment) for a set time, continuously, at a specific pressure setting.

Drain Mode: Allows a user to connect a Hose with a special Hose Adapter (purchased separately) to the unit, enter Drain Mode and have the unit empty the water out of the ice box through the Hose. Drain Mode can be accessed by pressing the program key and toggling through all six programs. To empty water in the system while in Drain Mode, press the program key until you reach Drain Mode, attach the Hose Adapter to the Connector Hose, place the Hose Adapter over a sink, and press the Play button. Drain Mode will run the Control Unit's fluid pump for up to six minutes (long enough to fully empty the ice box). Drain Mode is indicated by the following icons:



BUTTONS

















	Power: Use this button to turn the Control Unit on and off.
	Program: Use this button to select one of the available Programs or to return to Manual Mode. See page 11 in this manual for more information on Programs.
	Play/Pause: Use this button to start or pause a treatment.
	Add Time: Use this button to add time in Manual Mode (does not work in Program Mode). You can add up to 90 minutes. Treatment must be paused in order to add or subtract time.
	Subtract Time: Use this button to reduce time in Manual Mode (does not work in Program Mode). You can subtract up to 90 minutes. Treatment must be paused in order to add or subtract time.
	Pressure Selection: Use this button to select one of four pressure settings: No Pressure, Low Pressure (5-15 mmHg), Medium Pressure (5-50 mmHg), and High Pressure (5-75 mmHg). Pressure selection is not available in Program Mode. Treatment must be paused to change pressure settings.
	Volume: Use this button to select the option of sound or no sound. Push to mute sound. Alarms will still sound even with Volume off.
	C/F Button: Use this button to select either Celsius or Fahrenheit on the temperature display.
	Backlight: Use this button to turn the backlight on or off.



ADJUSTING TEMPERATURE

To adjust the temperature being applied during treatment, simply turn the temperature knob towards 3 snowflakes for the maximum amount of cold, or towards 1 snowflake for the least amount of cold. Notice that as you adjust the knob, the “Target Temperature” on the display will change. The system will automatically adjust to match the temperature you have selected.

TIP: The maximum amount of cold is dictated by the amount of ice in the reservoir and the setting of the temperature adjustment knob. You may need to stir or replenish the ice to achieve coldest temperatures. Ice will melt faster in the acute phases of injury as the Game Ready System is removing greater amounts of heat from the treatment site.

DISPLAY

<p>Status bar:</p> <p>Vol </p> <p>Manual  </p> <p>Program </p> <p>Pause </p> <p>Play </p>	<p>Vol </p> <p>Manual  </p> <p>Program </p> <p>Pause </p> <p>Play </p>	<p>Off (Mute)</p> <p>On</p> <p>Indicates selected mode.</p> <p>Indicates unit is paused.</p> <p>Indicates unit is running.</p>
<p>Other Icons:</p>	<p>Error </p> <p>Sleep </p> <p>Battery </p>	<p>Indicates an error. See troubleshooting pages 24-26 for error codes.</p> <p>Indicates sleep mode time.</p> <p>Indicates remaining battery capacity.</p>
<p>Temperature:</p>	 	<p>Actual Temperature: Approximate temperature of the water leaving the Control Unit.</p> <p>Target Temperature: Indicates the target temperature setting. The Control Unit will automatically match the Actual Temperature and Target Temperature as closely as possible.</p>

<p>When the system is running in Program Mode:</p>	<p>Sleep time count-down bars.</p> <p>Displays the amount of run time remaining.</p> <p>Run time count-down bars.</p> <p>Displays the amount of sleep time remaining.</p> 
<p>When the system is running in Manual Mode:</p>	<p>Displays the amount of run time remaining.</p> 

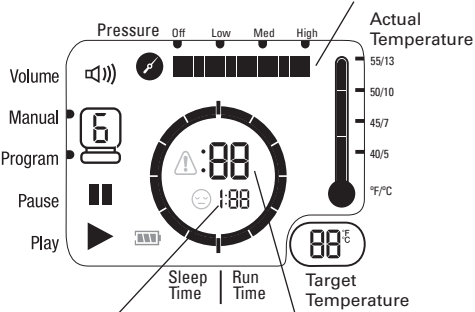
<p>When selecting a program:</p> 	<p>Displays pressure.</p>  <p>Displays amount of time unit will sleep.</p> <p>Displays amount of time unit will run.</p>
---	---

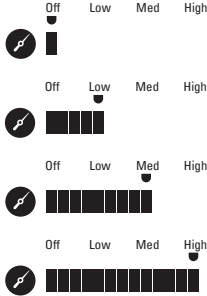
<p>Pressure:</p> 	<p>Off Low Med High</p> 
---	---

OPERATING THE SYSTEM

To operate your GRPro 2.1 System, you need:

- Control Unit filled with ice and water as indicated by the fill line labels within the reservoir. Optimal performance is achieved by first adding 1.5 liters of water, and then filling the reservoir to the top with ice.
- Game Ready supplied power supply.
- Connector Hose.
- Wrap (includes a Heat Exchanger and Sleeve).

Notes:

- The Wrap is comprised of an inner Heat Exchanger and an outer Sleeve. The combination of Sleeve and Heat Exchanger is referred to throughout this manual as a "Wrap." To ensure proper performance, be sure to use ATX Series Heat Exchangers.
- The Control Unit should be placed on a stable surface (such as the floor or a table) during use.
- Note that using the system in an environment with a high ambient temperature may affect its ability to provide adequate cooling, or may limit the ice life.
- If you will be using the system with a Game Ready optional battery pack (sold separately), please consult the instructions for use that accompany that battery pack.

Warning:

- Your GRPro 2.1 Control Unit should be plugged into a grounded electrical outlet prior to operation when using the FSP Power Supply. When using the Mega MDM-030-A120-5396 power supply, a grounded electrical outlet is not required.
- Position the Control Unit to minimize the risk of tripping over the Control Unit, Connector Hose, or power cord.

Precautions:

- Failure to properly follow the instructions of this manual and those of your medical provider may interfere with or prevent delivery of appropriate therapy.
- To avoid risk of electrical shock unplug the Control Unit from the electrical outlet prior to filling the Control Unit with ice and water.

- 1 Push the door release button to open the ice box door.

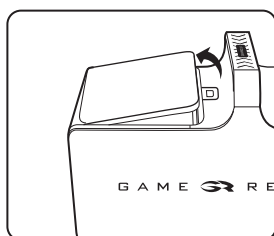
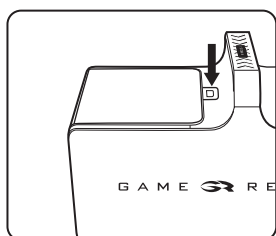

- 2 Add water to fill-line indicated on label within the reservoir. DO NOT OVERFILL. Add ice to top of reservoir.

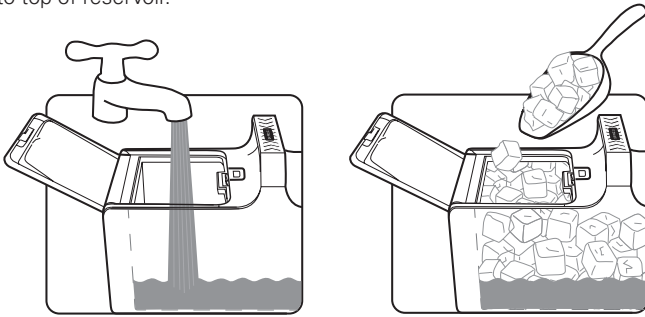

- 3 Close the ice box door. Make sure you hear it click.

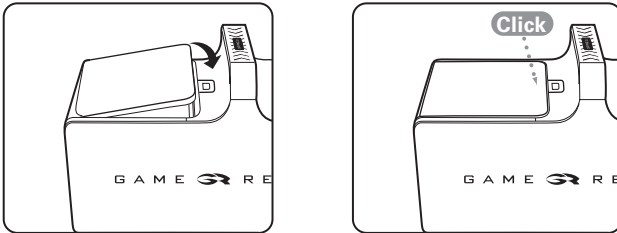

- 4 Place the Control Unit in the location where you plan to use it. The Control Unit should only be used in the upright orientation as shown. The Control Unit will leak if placed on its side.

- 5 Connect the AC Adapter to the receptacle on the end panel of the Control Unit, then plug the AC Adapter into an electrical outlet. The power indicator light (orange color) on the Control Unit should illuminate. Press the power button.  The screen should light up and the Control Unit should beep twice. The power indicator light should turn from orange to green. If you do not see these indicators, refer to "Control Unit will not turn on" on page 26 of the Troubleshooting Guide in this manual.

Note: The Control Unit should be turned on prior to attaching a Wrap.

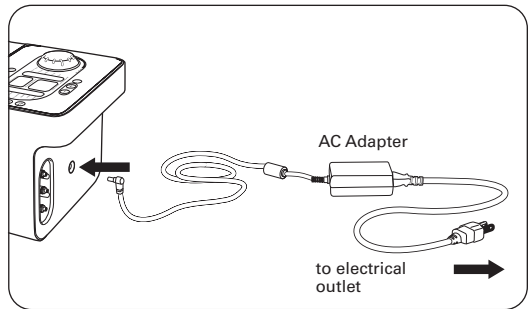

- 6 Connect the larger end of the Connector Hose (with the red button) to the Control Unit. Make sure you hear it click. To disconnect, simply press the red button and remove the connector from the Control Unit.

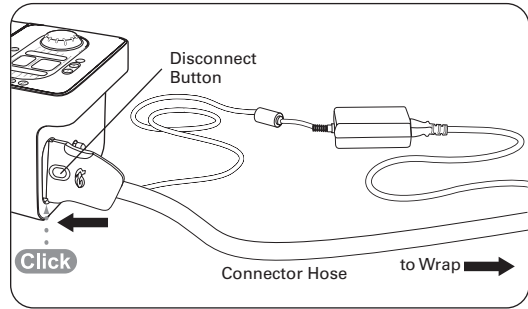

- 7 Apply the selected Wrap (consult the Use Guide accompanying each Wrap for application instructions). To ensure proper performance of the system, it is important to use ATX Series Heat Exchangers in your Wrap.

Caution:

- The Wrap is not sterile. Do not place directly against open wounds, sores, rashes, infections, or stitches. The Wrap may be applied over clothing or dressing.
- To ensure best fit, be sure the Wrap is completely deflated prior to each application.

- 8 Connect the smaller end of the Connector Hose (with a blue or gray button) to the Wrap. Make sure you hear it click. To disconnect, simply press the blue or gray button and remove the connector from the Wrap.

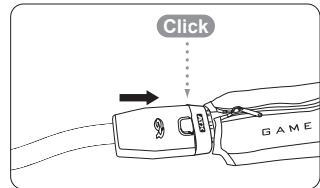
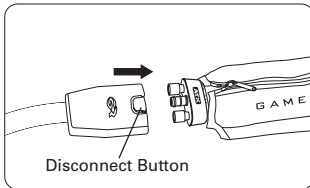



If you have any problems with the set-up of your GRPro 2.1 System, in the U.S. call Game Ready Customer Service at 1.888.426.3732 (+1.510.868.2100); from outside of the U.S. please contact your local distributor.

Warnings:



- Follow the treatment recommendations of your health care practitioner for the use of this device.
- Improper placement or prolonged use of the GRPro 2.1 could result in tissue damage.
- READ COMPLETE INDICATIONS, CONTRAINDICATIONS, CAUTIONS AND WARNINGS BEFORE USING THIS PRODUCT!

- 9** Manual ▶  Select the operating mode. You can choose either Manual Mode or Program Mode. Manual Mode allows you to customize the time and pressure settings. Program Mode allows you to select one of six automated programs that provide treatment for a set time interval then “sleep” (providing no treatment) for a set time, continuously, at a specific pressure setting (refer to list of available programs below). The unit automatically starts in Manual Mode.

Manual Mode:

	Set the time in five minute increments by pushing the +/- buttons.
	Set the pressure by pushing the pressure button. You can select from 4 pressure settings: No pressure, Low Pressure (5-15mmHg), (Medium Pressure (5-50mmHg), High Pressure (5-75mmHg).

Program Mode:

	Push the program button to enter Program Mode. In Program Mode, the unit will operate continuously according to the selected program. You will need to replenish ice and water as previously indicated in step 2.
	<p>You can select from the following programs: (Push the Program Button to scroll through the available programs.)</p> <p>Program 1: 30 minutes on, 30 minutes sleep. No pressure.</p> <p>Program 2: 30 minutes on, 30 minutes sleep. Low pressure.</p> <p>Program 3: 30 minutes on, 30 minutes sleep. Medium pressure.</p> <p>Program 4: 30 minutes on, 60 minutes sleep. No pressure.</p> <p>Program 5: 30 minutes on, 60 minutes sleep. Low pressure.</p> <p>Program 6: 30 minutes on, 60 minutes sleep. Medium pressure.</p> <p>Program d: Drain Mode. Please refer to page 5 in this manual for details.</p>

- 10**  Press play/pause button to start your Game Ready treatment with ACCEL Technology. Press play/pause at any time to stop your treatment.

- 11** Set to your target temperature (displayed in the Target Temperature window) by turning the knob. For coldest therapy, turn the knob clockwise towards three snowflakes. For warmer therapy, turn the knob counter-clockwise towards one snowflake.



- 12** Replenish ice and water levels as necessary, and indicated in Step 2, to maintain your target temperature.

- 13** After use:

- Unplug the AC Adapter and the Connector Hose from the Control Unit
- Push the door release button to open the door
- Carefully pour out the ice and water
- Wipe off any excess water

STORAGE

When you are done using the system for the day:

- Unplug the AC Adapter and the Connector Hose from the Control Unit.
- Push the door release button to open the door.
- Carefully pour out the ice and water.
- Wipe off any excess water.
- Store the Control Unit with the lid fully open to allow the interior to dry and preserve the reservoir seal. Store the Control Unit in the Carry Bag or in another safe location. Remember that your GRPro 2.1 Control Unit is a valuable piece of equipment and should be treated with great care, like a laptop computer.

System Storage Temperature: 33° - 120°F (1° - 50°C)

Relative Humidity: 10% - 95% non-condensing

Caution: Do not keep in extreme cold or hot temperatures (below 33°F or above 120°F or below 1° or above 50°C). Do not leave in a hot or freezing car. Do not leave the Control Unit in direct sunlight. The UV light may damage or discolor the Control Unit.

CLEANING

SYSTEM

If desired, the system (Control Unit, Hoses, and Wraps) can be flushed with a mixture of isopropyl alcohol and water, and run on no compression ("off"). This should be followed by running the Control Unit with clean water only on the no compression ("off") setting.

CONTROL UNIT

The exterior of the Control Unit and the visible interior surfaces of the reservoir can be cleaned with a soft cloth and one of the following cleaning agents:

- Mild detergent
- 70% Isopropyl alcohol
- Antifect® FF
- Mikrozid® Sensitive Wipes
- Quaternary ammonium (such as Virex® – typically only found in a clinical use setting)
- Cavicide®

Procedure:

- Follow the manufacturer's instructions and precautions for the cleaning agent you select.
- Apply the selected cleaner to a soft cloth and wipe down all surfaces of the Control Unit.
- Allow the Control Unit to dry thoroughly before storing it in the bag.
- The Control Unit should be cleaned as needed.

DO NOT USE:

- Phenolic-based disinfectants (such as Amphyl® – typically only found in a clinical use setting).
- Any solvent-based cleaners on the Control Unit. Doing so will damage the plastics and will void your warranty.
- Abrasive materials to clean the Control Unit. Doing so will damage the plastics and will void your warranty.

Caution: The Control Unit is not a waterproof device. Do not apply a direct stream of any liquid onto the Control Unit, submerge the Control Unit, or allow any liquid to pool on the surface of the front panel of the Control Unit.

CONNECTOR HOSE

The surface of the Connector Hose can be cleaned using a soft cloth and one of the following:

- Mild detergent
- Steri-Fab®
- Antifect® FF
- Mikrozyd® Sensitive Wipes
- 70% Isopropyl alcohol
- We do not recommend the use of quaternary ammonium (such as Virex®) or Cavicide®

DO NOT USE:

- Phenolic-based disinfectants (such as Amphyl® – typically only found in a clinical use setting).
- Any solvent based cleaners. Doing so will damage the plastics and will void your warranty.
- Abrasive materials. Doing so will damage the plastics and will void your warranty.
- Any petroleum based lubricants. Doing so will damage the o-rings and will void your warranty. If lubrication is required, the use of silicon spray is recommended.

WRAPS

Gently remove Heat Exchanger from the Sleeve. Hand wash the Sleeve in cold water, using a mild detergent or antibacterial soap. Do not use fabric softener. Hang to dry.

If needed, the external surface of the Heat Exchanger may be cleaned by wiping down with commercial non-bleach cleaning wipes or hand washed using a very small amount of mild detergent or antibacterial soap. **DO NOT MACHINE WASH.**

Refer to the Wrap Use Guide accompanying individual Wraps for more information.

CARRY BAG

The Carry Bag should be cleaned using a soft cloth or brush and a mild detergent. Febreze® or the equivalent can be used on the Bag if desired. If the Carry Bag has a biological material on the surface, Steri-Fab® may be used to decontaminate those surfaces.

Be sure to test any product on a small portion of the Bag to ensure that it will not cause damage.

Note: To operate the GRPro 2.1 System, you do not need to remove it from the Carry Bag. Simply unzip the Bag's main compartment and end panel. Fill the reservoir with ice and water. Attach the Connector Hose and the AC Adapter to the end panel of the Control Unit and plug the AC Adapter into an electrical outlet.

MAINTENANCE

The reservoir filter should be inspected, cleaned, and/or replaced as necessary.

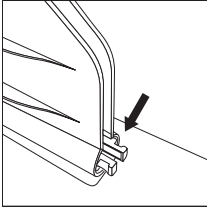

- 1** Identify the filter within the ice reservoir.

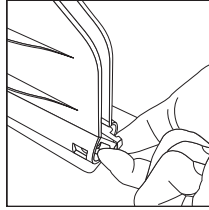

- 2** Using two fingers, grasp and squeeze the two protruding prongs.

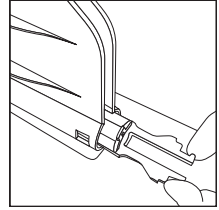

- 3** Slide the filter out.

- 4** Rinse debris from the filter and be sure there are no obvious signs of damage.

If you have questions or would like to order a new filter, in the U.S. call Game Ready Customer Service at 1.888.426.3732 (+1.510.868.2100); from outside of the U.S. please contact your local distributor.

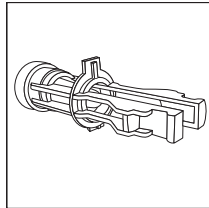

- 5** To replace the filter, or install a new filter, first ensure that the filter is oriented properly with the plastic tab facing up. If the filter is not oriented properly, the protruding tab will prevent the filter from sliding back into place.

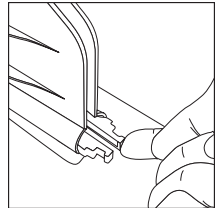

- 6** You will feel and hear the filter snap back into place.

Other than maintaining the reservoir filter, no product service or modification should be performed by the user. If your GRPro 2.1 System requires service, in the U.S. call Game Ready Customer Service at 1.888.426.3732 (+1.510.868.2100); from outside of the U.S. please contact your local distributor.

ACCESSORIES

The GRPro 2.1 Control Unit can be used with any of the following accessories:

- Any Game Ready Wrap using ATX Series Heat Exchangers (wraps made by any other manufacturer **CANNOT** be used with this system)
- Game Ready supplied Mega MDM-030-A120 power supply
- Game Ready supplied Connector Hose
- Game Ready Carry Bag
- Game Ready Drain Mode Adapter
- Game Ready Rechargeable Battery Pack

If long storage of the Battery Pack is required, it is recommended that the battery is periodically recharged to preserve the electronic integrity of the battery. Fully charge before use and every six (6) months.

INDICATIONS FOR USE

Caution: United States Federal Law restricts this device to sale by or on the order of a licensed health care practitioner.

- **Follow the treatment recommendations of your health care practitioner for duration and frequency of use for this device.**

The GRPro 2.1 System combines cold and compression therapies. It is intended to treat post-surgical and acute injuries to reduce edema, swelling, and pain for which cold and compression are indicated. It is intended to be used by or on the order of licensed healthcare professionals in hospitals, outpatient clinics, athletic training settings, or home settings.

CONTRAINDICATIONS

Important: Read the Wrap Use Guide for Wrap specific contraindications and warnings.

Compression Therapy using the Game Ready System or any compression therapy device should not be used in patients:

- Who are in the acute stages of inflammatory phlebitis in the affected region.
- Who have any current clinical signs suggestive of deep vein thrombosis in the affected region.
- Who have significant arteriosclerosis or other vascular ischemic disease in the affected region.
- Who have any significant risk factors or current clinical signs of embolism (e.g. pulmonary embolus, cerebral infarction, atrial fibrillation, endocarditis, myocardial infarction, or arteromatous embolic plaque).
- Who have a condition in which increased venous or lymphatic return is not desired in the affected extremity (e.g., carcinoma).
- Who have decompensated hypertonia in the affected region.
- Who has any condition that the clinician feels would contraindicate for the postoperative test or control treatments
- Who has any condition that would contraindicate using the Game Ready
- Who is currently enrolled in another clinical trial that could affect the outcome

Cryotherapy using the Game Ready System or any cryotherapy device should not be used in patients:

- Who have significant vascular impairment in the affected region (e.g., from prior frostbite, diabetes, arteriosclerosis or ischemia).
- Who have known hematological dyscrasias which affect thrombosis (e.g., paroxysmal cold hemoglobinuria, cryoglobulinemia, sickle-cell disease, serum cold agglutinins).

GENERAL WARNINGS AND CAUTIONS

WARNINGS

- Follow the treatment recommendations of your health care practitioner for duration and frequency of use for this device.
- Improper placement or prolonged use of the Game Ready System could result in tissue damage.
- Use extra caution during the immediate postoperative period, especially when sedated or on any medication that could alter normal pain sensation. Check the skin of the treated region frequently and use mid-to-higher (warmer) temperature range settings or leave more time between treatments, if necessary.
- A layer of clothing between Wrap and skin is required for all patients.
- During the course of therapy, patients should monitor the skin of the treated region, the surrounding area and the digits of the extremities of the treated limb (if applicable) for any burning, itching, increased swelling, or pain. If any of these signs are present, or any changes in skin appearance occur (such as blisters, increased redness, discoloration, or other noticeable skin changes), patients are advised to discontinue use and consult a physician.
- Game Ready Wraps are not sterile; do not place directly against open wounds, sores, rashes, infections, or stitches. The Wrap may be applied over clothing or dressing.
- Game Ready Wraps are available in multiple configurations but are not intended for all possible physiological uses. For example, the Ankle Wrap is not designed for use on the toes and the Back Wrap is not designed for use in the abdominal region.

Compression Therapy with the Game Ready System should be used only under the supervision of a licensed healthcare practitioner in patients:

- Who have an open wound in the affected region (the wound must be dressed prior to use of Game Ready).
- Who have an acute, unstable (untreated) fracture in the affected region.
- Who are children under 18 years old or patients who have cognitive disabilities or communication barriers, whether temporary (due to medication) or permanent.
- Who have a cardiac insufficiency or congestive heart failure (with associated edema in the extremities or lungs).
- Who have a localized unstable skin condition (e.g., dermatitis, vein ligation, gangrene, or recent skin graft) in the affected region.
- Who have erysipelas or other active infection in the affected region.

Cryotherapy with the Game Ready System should be used only under the supervision of a licensed healthcare practitioner in patients:

- Who have Raynaud's disease or cold hypersensitivity (cold urticaria).
- Who have hypertension or extreme low blood pressure.
- Who have diabetes.
- Who have compromised local circulation or neurologic impairment (including paralysis or localized compromise due to multiple surgical procedures) in the affected region.
- Who have a localized unstable skin condition (e.g., dermatitis, vein ligation, gangrene, or recent skin graft) in the affected region.
- Who have rheumatoid arthritis in the affected region.
- Who are children under 18 years old or patients who have cognitive disabilities or communication barriers, whether temporary (due to medication) or permanent.



WARNING: To comply with California Proposition 65, the following warning has been included: This product can expose you to chemicals including cadmium, chromium, lead, polybrominated biphenyls or mercury, which are known to the State of California to cause cancer or reproductive toxicity. For more information go to www.p65warnings.ca.gov.

CAUTIONS

- To avoid the risk of electrical shock, do not remove any panels from the Control Unit. Opening the case will void the Game Ready warranty. For all servicing and repair, in the U.S. call Game Ready Customer Service at 1.888.426.3732 (+1.510.868.2100); from outside of the U.S. please contact your local distributor.
- To avoid the risk of electrical shock, always turn off the system and disconnect the power line cord from its electrical outlet when not in use or before adding or emptying ice and water.
- Do not use any AC adapter other than that provided by Game Ready. Use of other adapters may result in electrical shock and will void the Game Ready warranty.
- To avoid damage to your product, do not operate the system without any water in the ice box.
- To avoid electrical shock, product malfunction or damage, never operate the system with damaged power cords or Connector Hoses, or other mechanical damage, or if the unit is otherwise not fully operational.
- To avoid potential damage to your product, do not pour hot water into the ice box. The system is not designed to operate, and has not been tested, with hot water.
- Do not use anything but ice and water in the ice box.
- To avoid damage to your product, do not pick up the Control Unit by the lid. Carry the Control Unit using the handle only.
- To avoid potential damage to your product, do not use other manufacturers' wraps with the Game Ready System.
- To avoid damage to your product, do not operate the Control Unit without a Connector Hose attached.
- To avoid injury, be careful not to trip over the system's power cords and Connector Hose.
- Monitor hose and cord placement when in use. Store hoses and cords when not in use to avoid potential of strangulation.
- Keep the system, including hoses and cords, away from children and pets.
- Use caution when handling small parts to reduce any possibility of swallowing or inhalation
- The GRPro 2.1 Control Unit is a technical medical device. To avoid damage to your product, handle it with the same care as you would a laptop computer. Do not drop it, kick it or otherwise abuse it unnecessarily. Such abuse will void all Game Ready warranties. Do not place the AC Adapter or Battery Pack inside the ice box for storage or transport.



- This symbol on the Control Unit or its packaging means that this product must not be disposed of with your household waste. To learn where to drop off your electrical and electronic waste, please contact your local city/municipal waste disposal service office or contact Game Ready for assistance.
- There are no special disposal requirements for the Wraps.

SPECIFICATIONS

Size: 16.25" length x 7.75" width x 9.25" height (413 x 197 x 235) mm, not including Carry Bag

Weight: 7.3 lb. empty, approximately 18 lb. full of ice and water

Pressure level: cycles from 5mm Hg up to 75mm Hg

AC power: 100-240 V~, 50-60 Hz, 1.6A

DC input: 12V/2.5 A

- The maximum operating temperature of the equipment is between 33.8-104°F (1-40°C).
- The maximum operating altitude of the equipment is 9,843 feet (3,000 meters).
- The expected service life of the Control Unit is 5 years. The expected service life of the parts and accessories shipped with the Control Unit is 2 Years.

UL CLASSIFICATION

Protection against electric shock:

The GRPro 2.1 System is considered to be Class II when connected to the Mega MDM-030-A120 power supply.

The MDM-030-A120 power supply is intended for home use.

Protection against harmful ingress of water:

This product provides ordinary protection against ingress of water. When used with the MDM-030-A120 power supply the device is classified to an IP22 rating, which is a protection against dripping water.

Pollution degree classification:

This product is classified as Pollution degree 2.

Degree of safety in the presence of flammable anesthetics or oxygen:

Not suitable for use in an oxygen enriched environment or in the presence of flammable anesthetics.

Electromagnetic interference:

This equipment has been tested and found to comply with the limits for medical devices in IEC 60601-1-2:2007 and IEC 60601-1-2:2014. These limits are designed to provide reasonable protection against harmful interference in a typical medical installation.

This equipment generates, uses and can radiate radio frequency energy and, if not installed and used in accordance with the instructions, may cause harmful interference to other devices in the vicinity. However, there is no guarantee that interference will not occur in a particular installation.

If this equipment does cause harmful interference to other devices, which can be determined by turning the equipment off and on, the user is encouraged to try to correct the interference by one or more of the following measures:

- Reorient or relocate the receiving device.
- Increase the separation between the equipment. Connect the equipment into an outlet on a circuit different from that to which the other device(s) are connected.
- Consult the manufacturer or field service technician for help.

The device is intended for use in orthopedic centers, therapy clinics, athletic training facilities, hospitals, nursing facilities, medical centers, as well as in patient homes. The device should not be used in an environment where the intensity of electromagnetic disturbance is high.

In the event the device experiences a loss of performance or degradation due to electromagnetic disturbance, the device is expected to continue to operate safely.

The device should not be used less than 30 cm (12 inches) away from any portable and mobile RF communications equipment.

ELECTROMAGNETIC COMPATIBILITY

Electromagnetic Compatibility Information According to IEC/EN 60601-1-2

Table 1 for Emissions

GUIDANCE AND MANUFACTURER'S DECLARATION – ELECTROMAGNETIC EMISSIONS		
The GRPro 2.1 is intended for use in the electromagnetic environment specified below. The customer or the user of the GRPro 2.1 should assure that it is used in such an environment.		
EMISSIONS TEST	COMPLIANCE	ELECTROMAGNETIC ENVIRONMENT – GUIDANCE
RF emissions CISPR 11	Group 1	The GRPro 2.1 uses RF energy only for its internal function. Therefore, its RF emissions are very low and are not likely to cause any interference in nearby electronic equipment.
RF emissions CISPR 11	Class B	The GRPro 2.1 is suitable for use in all establishments, including domestic establishments and those directly connected to the public low-voltage power supply network that supplies buildings used for domestic purposes.
Harmonic emissions IEC 61000-3-2	Class A	
Voltage fluctuations/ flicker emissions IEC 61000-3-3	Complies	

Table 2 for Transient Electromagnetic Immunity

GUIDANCE AND MANUFACTURER'S DECLARATION – ELECTROMAGNETIC IMMUNITY			
The GRPro 2.1 is intended for use in the electromagnetic environment specified below. The customer or the user of the GRPro 2.1 should assure that it is used in such an environment.			
IMMUNITY TEST	IEC 60601 TEST LEVEL	COMPLIANCE LEVEL	ELECTROMAGNETIC ENVIRONMENT – GUIDANCE
Electrostatic discharge (ESD) IEC 61000-4-2	± 6 kV contact ± 8 kV air	± 6 kV contact ± 8 kV air	Floors should be wood, concrete or ceramic tile. If floors are covered with synthetic material, the relative humidity should be at least 30%.
Electrical fast transient/burst IEC 61000-4-4	± 2 kV for power supply lines ± 1 kV for input/output lines	± 2 kV for power supply lines ± 1 kV for input/output lines	Mains power quality should be that of a typical commercial or hospital environment.
Surge IEC 61000-4-5	± 1 kV line(s) to line(s) ± 2 kV line(s) to earth	± 1 kV line(s) to line(s) ± 2 kV line(s) to earth	Mains power quality should be that of a typical commercial or hospital environment.
Voltage dips, short interruptions and voltage variations on power supply input lines IEC 61000-4-11	<5% U_T (>95% dip in U_T) for 0.5 cycle 40% U_T (60% dip in U_T) for 5 cycles 70% U_T (30% dip in U_T) for 25 cycles <5% U_T (>95% dip in U_T) for 5 s	<5% U_T (>95% dip in U_T) for 0.5 cycle 40% U_T (60% dip in U_T) for 5 cycles 70% U_T (30% dip in U_T) for 25 cycles <5% U_T (>95% dip in U_T) for 5 s	Mains power quality should be that of a typical commercial or hospital environment. If the user of the GRPro 2.1 requires continued operation during power mains interruptions, it is recommended that the GRPro 2.1 be powered from an uninterruptible power supply or a battery.
Power frequency (50/60 Hz) magnetic field IEC 61000-4-8	3 A/m	3 A/m	Power frequency magnetic fields should be at levels characteristic of a typical location in a typical commercial or hospital environment.
NOTE U_T is the AC mains voltage prior to application of the test level.			

Table 3 for RF Electromagnetic Immunity

GUIDANCE AND MANUFACTURER'S DECLARATION – ELECTROMAGNETIC IMMUNITY			
The GRPro 2.1 is intended for use in the electromagnetic environment specified below. The customer or the user of the GRPro 2.1 should assure that it is used in such an environment.			
IMMUNITY TEST	IEC 60601 TEST LEVEL	COMPLIANCE LEVEL	ELECTROMAGNETIC ENVIRONMENT – GUIDANCE
Conducted RF IEC 61000-4-6	3 Vrms 150 kHz to 80 MHz	3Vrms	Portable and mobile RF communications equipment should be used no closer to any part of the GRPro 2.1, including cables, than the recommended separation distance calculated from the equation applicable to the frequency of the transmitter. Recommended separation distance $d = 1.2 \sqrt{P}$ $d = 2.3 \sqrt{P}$ 800 MHz to 2.5 GHz where P is the maximum output power rating of the transmitter in watts (W) according to the transmitter manufacturer and d is the recommended separation distance in meters (m). Field strengths from fixed RF transmitters, as determined by an electromagnetic site survey, ^a should be less than the compliance level in each frequency range. ^b Interference may occur in the vicinity of equipment marked with the following symbol: 
Radiated RF IEC 61000-4-3	3 V/m 80 MHz to 2.5 GHz	3 V/m	
NOTE 1 At 80 MHz and 800 MHz, the higher frequency range applies.			
NOTE 2 These guidelines may not apply in all situations. Electromagnetic propagation is affected by absorption and reflection from structures, objects and people.			
^a Field strengths from fixed transmitters, such as base stations for radio (cellular/cordless) telephones and land mobile radios, amateur radio, AM and FM radio broadcast and TV broadcast cannot be predicted theoretically with accuracy. To assess the electromagnetic environment due to fixed RF transmitters, an electromagnetic site survey should be considered. If the measured field strength in the location in which the GRPro 2.1 is used exceeds the applicable RF compliance level above, the GRPro 2.1 should be observed to verify normal operation. If abnormal performance is observed, additional measures may be necessary, such as re-orienting or relocating the GRPro 2.1.			
^b Over the frequency range 150 kHz to 80 MHz, field strengths should be less than 3 V/m.			

Table 4 for RF Immunity

RECOMMENDED SEPARATION DISTANCES BETWEEN PORTABLE AND MOBILE RF COMMUNICATIONS EQUIPMENT AND THE GRPRO 2.1			
<p>The GRPro 2.1 is intended for use in an electromagnetic environment in which radiated RF disturbances are controlled. The customer or the user of the GRPro 2.1 can help prevent electromagnetic interference by maintaining a minimum distance between portable and mobile RF communications equipment (transmitters) and the GRPro 2.1 as recommended below, according to the maximum output power of the communications equipment.</p>			
RATED MAXIMUM OUTPUT POWER OF TRANSMITTER W	SEPARATION DISTANCE ACCORDING TO FREQUENCY OF TRANSMITTER		
	150 KHZ TO 80 MHZ $d = 1.2 \sqrt{P}$	80 MHZ TO 800 MHZ $d = 1.2 \sqrt{P}$	800 MHZ TO 2.5 GHZ $d = 2.3 \sqrt{P}$
0.01	0.12	0.12	0.23
0.1	0.38	0.38	0.73
1	1.2	1.2	2.3
10	3.8	3.8	7.3
100	12	12	23
<p>For transmitters rated at a maximum output power not listed above, the recommended separation distance d in meters (m) can be estimated using the equation applicable to the frequency of the transmitter, where P is the maximum output power rating of the transmitter in watts (W) according to the transmitter manufacturer.</p> <p>NOTE 1: At 80 MHz and 800 MHz, the separation distance for the higher frequency range applies.</p> <p>NOTE 2: These guidelines may not apply in all situations. Electromagnetic propagation is affected by absorption and reflection from structures, objects and people.</p>			

WARNINGS:

Medical Electrical Equipment needs special precautions regarding EMC and needs to be installed and put into service according to the EMC information provided in the User's Manual.

Portable and mobile RF communications equipment can affect Medical Electrical Equipment.

The GRPro 2.1 System has to be powered with the AC adapter FSP Group Inc. model FSP 030-RCAM or Mega MDM-030-A120-5396 power supply in order to be compliant with IEC/EN 60601-1-2 section 6.1 and 6.2.

The use of accessories, transducers and cables other than those specified and sold by the manufacturer of the GRPro 2.1 System as replacement parts for internal components may result in increased emissions or decreased immunity of the medical electrical system.

The GRPro 2.1 System should not be used adjacent to or stacked with other equipment. If adjacent or stacked use is necessary, the GRPro 2.1 System should be observed to verify normal operation in the configuration in which it will be used.

WARNING: The essential performance of the GRPro 2.1 System is:

Pneumatic Compression Cycles:



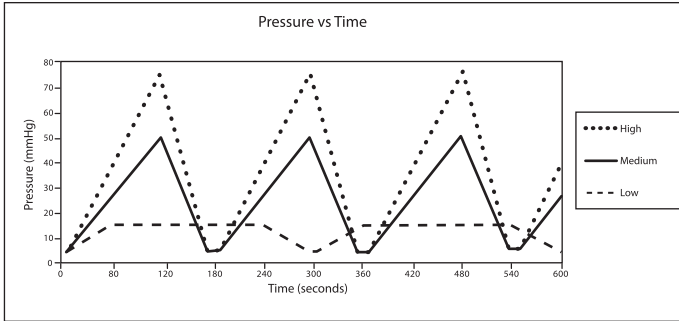

- High: cyclic 5-75mm Hg
- Med: cyclic 5-50 mm Hg
- Low: cyclic 5-15 mm Hg
- NO Pressure: Wrap shall be vented to atmosphere
- Air Pressure Accuracy: ± 10 mm Hg











The cooling temperature of the circulating ice water will be adjustable between 34°F (1°C) and 50°F (10°C) as long as the ice water in the ice box is supplied with sufficient amount of ice.





- Water Temperature Accuracy: ± 4 °F (± 2.2 °C)

TROUBLESHOOTING

ERROR	WHAT DOES IT MEAN?	WHAT CAN I DO?
 01	<p>Air Pressure Sensor: The Control Unit has detected a problem calibrating the air pressure circuit on start-up.</p>	<ul style="list-style-type: none"> • This is most likely to occur if you have restarted the system with an inflated Wrap attached. • Detach the Wrap, pressing it flat to expel the air accumulated inside and try again.
 02	<p>Self-Test Error – Air Pump: The Control Unit has detected an electronic problem in the air circuit on start-up.</p>	<ul style="list-style-type: none"> • Disconnect the Wrap from the Control Unit. • Turn the Control Unit off and on again without a Wrap connected. • Reconnect the Wrap and resume treatment. • If the problem persists, contact Customer Service.
 04	<p>Dry Pump: The Control Unit has detected a dry pump. In order to prevent possible damage to the fluid pump, the unit will stop therapy.</p>	<ul style="list-style-type: none"> • Be sure you are using ATX Series Heat Exchangers. • Note that if you are using new Wraps, the water in the reservoir may have been depleted and causing this error. Make sure there is adequate water in the reservoir based on the fill line indicator label. Refer to instructions for priming a Wrap below. • Verify that the ice box filter is not clogged (refer to filter maintenance instructions on page 14). • Make sure there are no kinks in the Wrap or Connector Hose. • Turn the Control Unit off and on again. • Disconnect and reconnect the hose from the Control Unit and the Wrap, verifying that an audible “click” is heard at both connection points. • Prime the Wrap using the following steps: <ul style="list-style-type: none"> - Select “Off” (No Pressure). - Attach the hose to the unit and the Wrap. - Lay the Wrap open and flat next to or lower than the Control Unit (not on the body). - Run the system for 2 minutes. • Prime the Control Unit using the following steps: <ul style="list-style-type: none"> - Disconnect the hose from the Control Unit. - Now, look at the Wrap connection location on the Control Unit. On the top valve, push the white prong in so that it is flush with the metal connector. - Make sure you are not fully covering the opening in the prong. - Push start, and water should squirt out of the valve. - Restart the system.
 06	<p>Over Pressure: Indicates that the Control Unit has exceeded the target air pressure.</p>	<ul style="list-style-type: none"> • Turn the Control Unit off and back on. • Make sure the Wrap is applied securely. • Do not make sudden movements during treatments. Rapid shifting in position may produce a quick change in pressure in the Wrap and cause this error.

ERROR	WHAT DOES IT MEAN?	WHAT CAN I DO?
 	<p>Under Pressure: The Control Unit can't reach its target maximum compression. This often indicates that there is a leak in the pneumatic compression circuit, either in the Connector Hose, Wrap or Control Unit. Or it may occur because the hook and loop fastener on your Wrap has worn out.</p>	<ul style="list-style-type: none"> • Make sure the Wrap is applied securely. • Try using a different Wrap and Hose to isolate which component may be producing the error. For example, an error which occurs with a Shoulder Wrap but not a Knee Wrap may indicate that the Shoulder Wrap is causing the error: not the Control Unit. • If using a Dual Hose, make sure you have two Wraps attached.
 	<p>Deflation Error: The Control Unit has detected that the Wrap has not properly deflated.</p>	<ul style="list-style-type: none"> • Turn the Control Unit off. • If there is air left in the Wrap, disconnect the Wrap from the Connector Hose and manually deflate the Wrap by applying pressure to it. • Reconnect the Hose to the Wrap and reapply the Wrap to the body. • Turn the Control Unit on and press play/pause. • Make sure the Wrap is applied securely against the body. • If possible, try using a different Wrap and Hose to isolate which component may be producing the error. For example, an error which occurs with a Shoulder Wrap but not a Knee Wrap may indicate that the Shoulder Wrap is causing the error: not the Knee Wrap or Control Unit.
 	<p>Pump Performance Error: The Control Unit has determined that the fluid pump may be working too hard. This could be caused by ice or debris in the fluid circuit. In order to prevent possible damage to the fluid pump, the unit will stop therapy.</p>	<ul style="list-style-type: none"> • Turn the Control Unit off and back on again. • Reapply the Wrap, making sure to follow all application instructions accompanying the Wrap. • Disconnect and reconnect the hose from the Control Unit and the Wrap, verifying that an audible "click" is heard at both connection points. • If that does not solve the problem turn the Control Unit off for 20 minutes (to let the pump cool down) before turning it on again to try again.
 	<p>Low Flow: Control Unit has detected something blocking the water flow.</p>	<ul style="list-style-type: none"> • Be sure you are using ATX Series Heat Exchangers. • Check all hose connections. • Disconnect and reconnect Wrap from Connector Hose. • Make sure there is water in the ice box. • Verify that the ice box filter is not clogged. • Make sure there are no kinks in the Wrap or Connector Hose. • Reapply the Wrap snugly, making sure to follow all application instructions accompanying the Wrap. • Turn the Control Unit off and on again. • Disconnect and reconnect the hose from the Control Unit and the Wrap.

Need more help with a problem? In the U.S. call Game Ready Customer Service at 1.888.426.3732 (+1.510.868.2100); from outside of the U.S. please contact your local distributor.

ERROR	WHAT DOES IT MEAN?	WHAT CAN I DO?
 	<p>Self-Test Error – Fluid Circuit: The Control Unit has detected an electronic problem in the fluid circuit on start-up.</p>	<ul style="list-style-type: none"> • Turn off the Control Unit. • Turn the Control Unit back on and resume treatment. • If the problem persists, contact Customer Service.
 	<p>Temperature Calibration Error: The Control Unit has detected a failure in the Temperature Control circuit or is being operated outside of the advised temperature range (33.8-104 degrees Fahrenheit).</p>	<ul style="list-style-type: none"> • Be sure you are operating the system within the advised temperature range of 33.8-104 degrees Fahrenheit and storing the system within the advised temperature range of 33-120 degrees Fahrenheit. • Turn the Control Unit off. • Fill the Control Unit with ice and water per the label instructions inside the reservoir. • Turn the unit back on again and push Play/Pause. • Repeat this process up to three times. • If the problem persists, contact Customer Service.
	<p>Control Unit will not turn on:</p>	<ul style="list-style-type: none"> • Press the power button. If no orange or green light is illuminated, make sure the AC Adapter is plugged into a working electrical outlet and all connections are secure. (Test outlet with another electrical device.) • Press the power button again. If the Control Unit still will not turn on, call Customer Service.
	<p>Control Unit won't reach Target Temperature, or temperature is unstable:</p>	<p>The fill-line labels within the reservoir indicate an ice/water ratio that will assist the Control Unit in achieving the temperature you've specified using the Temperature Knob. If you have filled the Control Unit according to the fill-line labels and are still unable to achieve your desired target temperature, try the following steps:</p> <ul style="list-style-type: none"> • If you are still unable to achieve WARMER temperatures, be sure the Temperature Knob is turned to full warm, use less ice, and reduce the amount of water if necessary. • If you are still unable to achieve COLDER temperatures, be sure the you are using ATX Series Heat Exchangers. Confirm that the Temperature Knob is set to full cold and that the reservoir is full of ice, replenishing frequently and stirring the reservoir to break up large formations of ice if necessary. Make sure there are no kinks in the Wrap or Connector Hose. Reapply the Wrap, making sure to follow all accompanying application instructions. Finally, if you still cannot achieve the coldest temperature desired, adding more water than what is indicated by the reservoir fill-line labels may also allow the Control Unit to reach colder temperatures. To achieve this effect, water may be added to the top of the ice level. <p>CAUTION: By overfilling the reservoir as in the last step, the temperature control feature of the system will not work and the Control Unit will be administering therapy at "full cold." Consult the Warnings on page 16 to make sure you take proper steps to minimize the risk of injury.</p>

WARRANTY

MANUFACTURER'S WARRANTY

CoolSystems warrants that the GRPro 2.1 Control Unit, if properly used, will be free from defects in material and workmanship for a period of two (2) years after the date the GRPro 2.1 Control Unit was purchased. If the GRPro 2.1 Control Unit, which is the subject of this Limited Warranty, malfunctions during the warranty period for reasons covered by this Limited Warranty, CoolSystems, at its options, will:

- REPAIR the GRPro 2.1 Control Unit OR
- REPLACE the GRPro 2.1 Control Unit with another GRPro 2.1 Control Unit.

THIS LIMITED WARRANTY AND ANY IMPLIED WARRANTIES THAT MAY EXIST UNDER STATE LAW APPLY ONLY TO THE ORIGINAL PURCHASER OF THE GRPRO 2.1 CONTROL UNIT AND ARE NON-TRANSFERABLE.

Extent of Limited Warranty

This limited warranty does not cover damages due to external causes, including, without limitation, accident, usage not in accordance with product instructions, misuse, neglect, alteration or repair.

How to Obtain Warranty Service

To obtain warranty service, in the U.S. call Game Ready Customer Service at 1.888.426.3732 (+1.510.868.2100); from outside of the U.S. please contact your local distributor. If you are not sure who the local distributor is, call Game Ready Customer Service at +1.510.868.2100 and we will refer you to one. You must have returned the Warranty Registration card to CoolSystems within thirty (30) days from the date of purchase to qualify for warranty service. If you qualify for warranty service from CoolSystems, you will be issued a Returned Material Authorization (RMA) number. When you return the GRPro 2.1 Control Unit to CoolSystems, you must write the RMA number on the outside of the package. CoolSystems will not accept returned GRPro 2.1 Control Units without an RMA number on the package. If you return the GRPro 2.1 Control Unit to CoolSystems, you must assume the risk of damage or loss during shipping. You must use the original packaging or the equivalent. CoolSystems may require you to verify in writing that you are the original purchaser of the GRPro 2.1 Control Unit. CoolSystems may elect to replace or repair the GRPro 2.1 Control Unit with either a new or reconditioned product. The returned product shall become CoolSystems' property upon receipt. The replacement GRPro 2.1 Control Unit is warranted under this written warranty and is subject to the same limitations and exclusions for the remainder of the original warranty period. THIS WARRANTY IS NOT TRANSFERABLE.

WARRANTY LIMITATIONS AND EXCLUSIONS

THESE WARRANTIES REPLACE ALL OTHER WARRANTIES, EXPRESS OR IMPLIED INCLUDING, BUT NOT LIMITED TO, THE IMPLIED WARRANTIES OF MERCHANTABILITY AND FITNESS FOR A PARTICULAR PURPOSE. COOLSYSTEMS MAKES NO EXPRESS WARRANTIES BEYOND THOSE STATED HERE. COOLSYSTEMS DISCLAIMS ALL OTHER WARRANTIES, EXPRESS OR IMPLIED INCLUDING, WITHOUT LIMITATION, IMPLIED WARRANTIES OF MERCHANTABILITY AND FITNESS FOR A PARTICULAR PURPOSE. SOME JURISDICTIONS DO NOT ALLOW THE EXCLUSION OF IMPLIED WARRANTIES SO THIS LIMITATION MAY NOT APPLY TO YOU. ALL EXPRESS AND IMPLIED WARRANTIES ARE LIMITED IN DURATION TO THE LIMITED WARRANTY PERIOD. NO WARRANTIES APPLY AFTER THAT PERIOD. SOME JURISDICTIONS DO NOT ALLOW LIMITATIONS ON HOW LONG AN IMPLIED WARRANTY LASTS, SO THIS LIMITATION MAY NOT APPLY TO YOU.

LIMITATIONS OF LIABILITY

COOLSYSTEMS' RESPONSIBILITY UNDER THIS, OR ANY OTHER WARRANTY, IMPLIED OR EXPRESS, IS LIMITED TO REPAIR OR REPLACEMENT, AS SET FORTH ABOVE. THESE REMEDIES ARE THE SOLE AND EXCLUSIVE REMEDIES FOR ANY BREACH OF WARRANTY. COOLSYSTEMS IS NOT RESPONSIBLE FOR DIRECT, SPECIAL, INCIDENTAL, OR CONSEQUENTIAL DAMAGES RESULTING FROM ANY BREACH OF WARRANTY OR UNDER ANY OTHER LEGAL THEORY INCLUDING, BUT NOT LIMITED TO, LOST PROFITS, DOWNTIME, GOODWILL, AND DAMAGE TO OR REPLACEMENT OF EQUIPMENT AND PROPERTY. SOME JURISDICTIONS DO NOT ALLOW THE EXCLUSION OR LIMITATION OF INCIDENTAL OR CONSEQUENTIAL DAMAGES, SO THE ABOVE LIMITATIONS OR EXCLUSIONS MAY NOT APPLY TO YOU. THIS LIMITED WARRANTY GIVES YOU SPECIFIC RIGHTS, AND YOU MAY ALSO HAVE OTHER RIGHTS THAT VARY FROM JURISDICTION TO JURISDICTION.

WARRANTY REGISTRATION

The GRPro 2.1 Control Unit comes with a 2-year warranty from date of purchase. The Heat Exchanger, Connector Hose, AC Adapter, and Power Cord come with a 1-year warranty. In the case of a manufacturer's defect, the Wrap sleeve and sleeve accessories may be returned within 7 days of purchase.

REGISTRATION

Please complete the Warranty Registration within 30 days for both the GRPro 2.1 Control Unit and the Wraps online at www.gameready.com. You will need the following information to complete your Warranty Registration: **The Control Unit's model number (REF) and its serial number (SN)**. These numbers are located on the label on the bottom of the Control Unit. Simply go to www.gameready.com, visit the Product Registration page, fill out the form and submit your information.

EXTENDED WARRANTIES

Extended Warranties are available for the GRPro 2.1 System. For details and information, in the U.S. call Game Ready Customer Service at 1.888.426.3732 (+1.510.868.2100); from outside of the U.S. please contact your local distributor.

A list of current patent(s) covering Game Ready technology can be found at: www.gameready.com/patents.



EMERGO EUROPE
Prinsessegracht 20
2514 AP The Hague
The Netherlands

EMERGO AUSTRALIA
201 Sussex Street
Darling Park
Tower II, Level 20
Sydney NSW 2000
Australia



G A M E  R E A D Y[®]

 COOLSYSTEMS[®], INC.
DBA Game Ready[®]
1800 Sutter Street, Suite 500
Concord, CA 94520 USA
1.888.GAMEREADEY +1.510.868.2100
www.gameready.com